

HITACHI
Inspire the Next

VARIABLE FREQUENCY DRIVE

SJ700 & L700 *series*

POWERFUL INVERTER



 Hitachi Industrial Equipment Systems Co., Ltd.

High performance, powerful

High starting Torque, Powerful Drive and easy setting

High starting Torque SJ L

Improved Sensorless Vector Control and Auto Tuning produce high starting torque of 200% or more at 0.3Hz.*1
Easy setup of motor constants
Ideal for applications which need high torque, such as cranes, extruders and lifts.

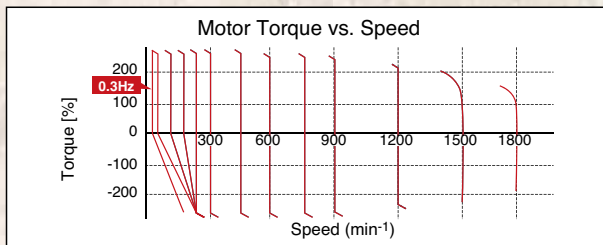

*1 Starting torque

Series	Applicable motor	Starting torque
SJ700	0.4 to 55kW	0.3Hz/200%
	75 to 132kW	0.3Hz/180%
	185 to 400kW	0.3Hz/150%
L700	11 to 75kW	0.5Hz/150%
	90 to 160kW	0.5Hz/120%

Hitachi exclusive 0Hz Domain sensorless vector control SJ

Develops 150%*2 torque at 0Hz speed reference

Ideal for cranes and other applications that require high torque at starting.

*2 when inverter is one frame size larger than motor.

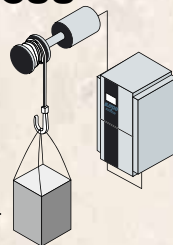

Position Control Function SJ

The SJ700, with optional feedback board installed, together with an encoder-equipped motor can perform position control.

For many applications, suitable performance can be achieved at a lower cost than servo systems.

Based on your four motion parameters (position command, speed command, acceleration time and deceleration time), the SJ700 will move an object from original position A to target position B. After the movement, the inverter keeps servo lock status.

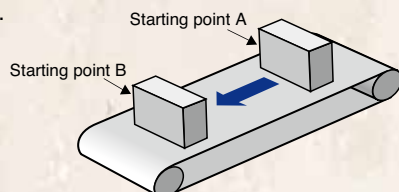

Trip avoidance function

Over current & voltage suppress function SJ L

Higher internal calculation speed improves current control performance.

Over-current suppress and Over-voltage suppress functions avoid inverter trip during acceleration and deceleration.

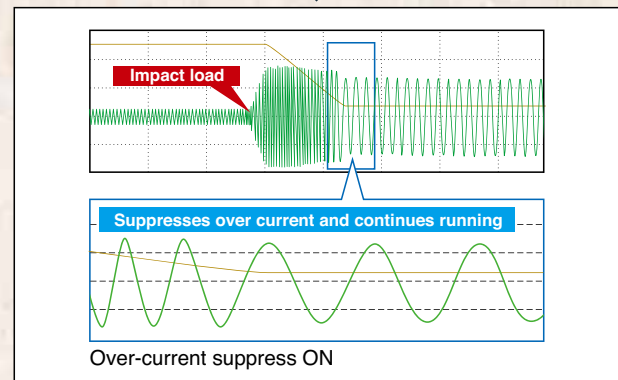
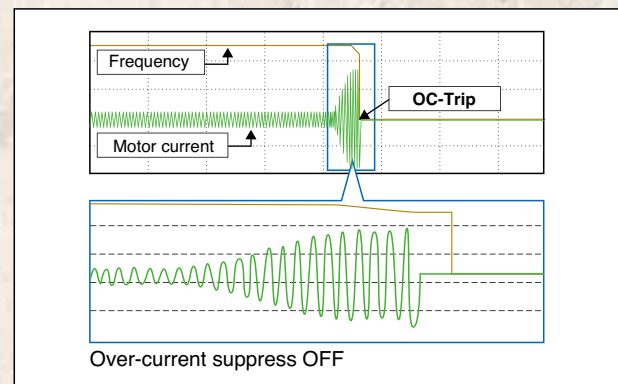

DC Bus AVR Function During Deceleration SJ L

The SJ700 controls deceleration time so that the DC bus voltage does not exceed the over-voltage trip level, providing trip-less operation during deceleration.

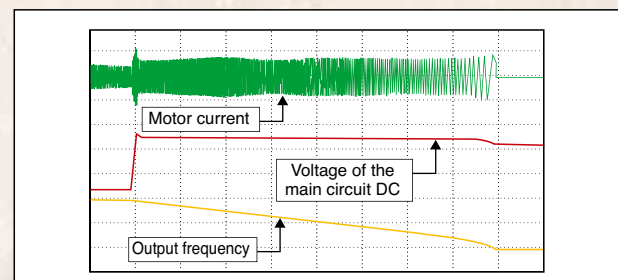

functions, yet user friendly.

★ **SJ** =SJ700 Series **L** =L700 Series

Programming [EzSQ: Easy Sequence] function

Inverter control by Built-in Programming function **SJ L**

Sequence operation is realized by downloading to an inverter a program created with Hitachi's Pro Drive Next software. Tailor inverter operation to meet changing process requirements, and replace separate PLCs in some cases. By simplifying or eliminating external hardware, significant cost savings can be achieved. Password function is incorporated to provide security for proprietary program data against loss or unauthorized modification.

Typical Example - Replacing External Relay Circuit

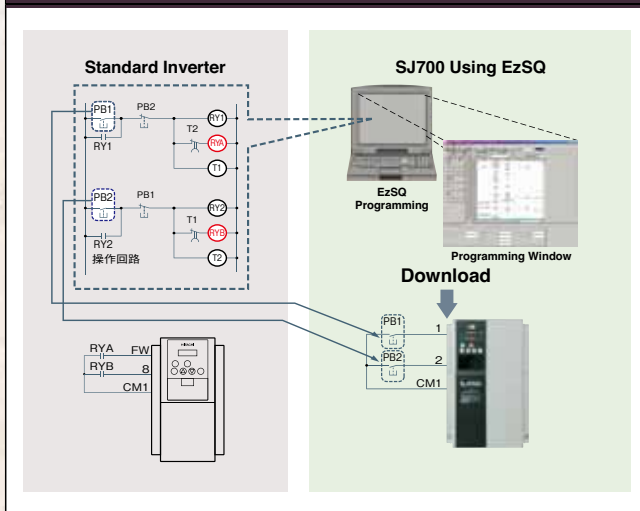

Item	Description		
Language Spec	Language type	BASIC Like	
	Supported Device	Windows(DOS/V)OS:Windows2000, WindowsXP	
	Memory area	1,024 steps or 6k byte (Smaller of these)Program is stored in internal of inverter.	
	Programming environment	Editor(Windows), Display(Windows) Grammar check(Windows) Program download/upload, All clear	
	Executable format	Interpreter 2.0ms/command (Sub routine supported. 8 nested)	
I/O function	External digital contact input	Contact signal/Open collector signal input (Internal DC24V power supply available)	
		Program RUN command FW terminal is reserved	
	External analog input	General-purpose input Maximum of 8 point(X(00)-X(07))	
		XA(0) : 0-10V (O terminal)	
XA(1) : 4-20mA (OI terminal) XA(2) : 0-10V (O2 terminal)			
External output	General-purpose output terminal Maximum of 8 point(Y(00)-Y(05))		
	External analog output	YA(0) : Setup for FM terminal is possible.	
		YA(1) : Setup for AM terminal is possible.	
YA(2) : Setup for AMI terminal is possible.			
Command	Programmable flow control <Loop, Unconditional jump, conditional jump, Time control, Sub routine, Others>		
	Operation command <+, -, *, /, substitution, mod, abs>		
	I/O control(Bit input, Word input, Bit output, Word output)		
	Timer control <on delay, off delay>		
	Inverter parameter setting		
Reserved word	User	U(00)-U(31)/32 point	
	Timer	UL(00)-UL(07)/8 point	
	Set frequency	SET-Freq	
	Acceleration time	ACCEL	
	Deceleration time	DECEL	
	Variable	Monitor	Output frequency, Output current, Rotative direction, PID feedback, Converted frequency, Output torque, Output voltage, Power, Cumulative RUN time, Cumulative power-on time, trip
		General-purpose input contact	X(00)-X(07)/8 point
		General-purpose output contact	Y(00)-Y(05)/6 point(1 point is relay output)
		Internal user	UB(00)-UB(07)/8 point
		Internal timer contact	TD(0)-TD(7)/8 point
Inverter input and output		In a remote operator display code.	

* Windows® is a registered trademark of Microsoft Corporation.U.S.A and other countries.

EMC Filter & Brake circuit integrated as Standard

Built-in EMC Filter up to 150kW* **SJ L**

Cost and space reduction compared with external EMC Filter. Reduces electromagnetic noise. Meets EN61800-3 2nd-Environment

* SJ700: European Version and Japanese Version does not have 150kW
L700: All models

Brake circuit up to 22kW* **SJ L**

Cost and Space reduction compared with external Braking Controller.

* L700: Up to 30kW

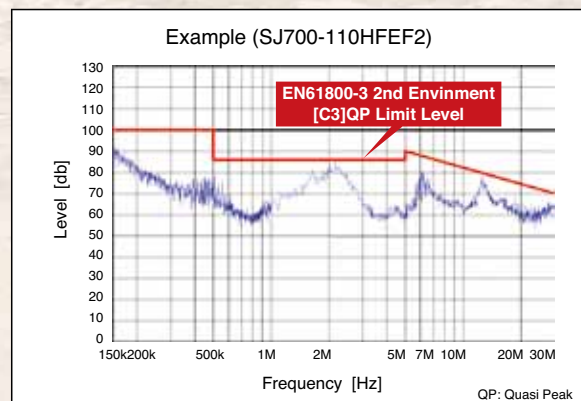

Ease of Maintenance

Easy-removable construction for maintenance



Field replacement of cooling fan(s) and DC bus capacitors can be accomplished in a fraction of the time.

Using Logic terminal move to SJ700 without wiring change.
Read SJ300 Parameter by WOP remote operator and write them in to SJ700



Easy-removable Cooling Fan



Easy-removable Dc bus Capacitors (SJ700: above 15kW L700: above 18.5kW)

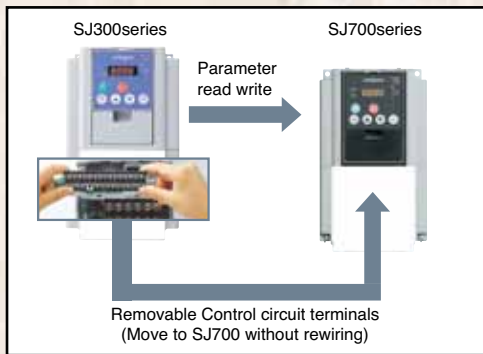

*1 Control circuit terminals comparison table

Series	Input terminals	Output terminals
SJ700	9terminals (Intelligent 8terminals,FW)	5terminals (Open collector outputs)
L700		
SJ300		
L300P	6terminals (Intelligent 5terminals,FW)	2terminals (Relay outputs)

Long life time components & Life time warning function



Long life time components

Design lifetime 10 Years or more for Dc bus capacitors & Cooling Fan.

Cooling Fan ON/OFF control function for longer fan life.

*Ambient temperature: Average 40 deg C (L700: 30 deg C)
(no corrosive gases, oil mist or dust)

Design lifetime is calculated, and not guaranteed.

Life time warning function

Perform preventive maintenance before a failure occurs using the Lifetime Warning function.

DC bus capacitor, cooling fan, heat sink temperature and motor temperature can be monitored in order to replace components prior to failure.

Easy Operation

User selection of Displayed Parameters



Data comparison function

Allows display of only parameters changed from default.

User selected function

Display of up to 12 User Defined Parameters U001 to U012.

Basic mode (default)

Basic display mode for commonly used parameters.

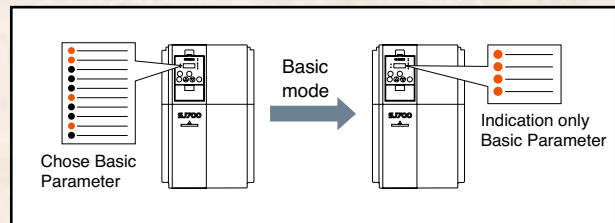

Other Functions

- The direct input of function code selection is possible rather than scrolling through the list.
- Holding down the function key for 3 seconds, causes the display to jump to output frequency monitor (d001) mode from any menu location.

Network compatibility

A serial RS-485 Modbus-RTU port is standard.



The SJ700 can communicate with DeviceNet, PROFIBUS-DP, and other networks with communication options.

-DeviceNet is a trade mark of Open DeviceNet Vender Association, Inc.

-PROFIBUS-DP is a registered trade mark of PROFIBUS Nutzer Organization

Simple & Low cost wiring, Ease of installation and replacement



Global standards

Conformity to global standards

CE, UL, c-UL, C-Tick approvals.



Logic input & output Terminal apply sink & source logic

Wide Input power voltage range

Input voltage 240V for 200V class and 480V for 400V class as standard. 

Environmental Friendliness

Micro Surge Voltage suppress function

Hitachi original PWM control method limits motor terminal voltage to less than two of inverter DC bus voltage. Lower than Hitachi motor Max. insulation voltage (1,250V) (During regeneration, the motor terminal voltage may exceed the motor maximum insulation voltage (1,250V))

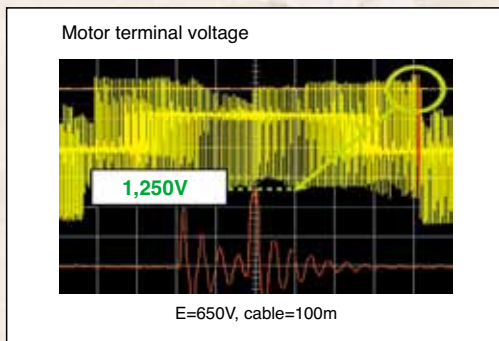

EU RoHS compliant

EU RoHS compliant (except solder in power module)

Improvement of environment

Varnish coating of internal PC board & plating of main circuit copper bus bar are standard.

Versatile Functions

Instantaneous Power Failure Disregard Function

The SJ700 ignores instantaneous power failure when power fluctuation happens frequently, as long as DC bus voltage remains higher than under-voltage trip level.

Emergency stop

Shuts down the inverter by hardware, bypassing the CPU, to achieve a reliable, emergency stop function.

Intelligent input terminal and output terminal ON/OFF delay function

Helps simplify external circuits.

Active frequency matching function

Motor frequency match restart function operates effectively even without motor residual voltage.

Controlled deceleration and stop on power loss

Analog Input Disconnection Detection Function

The SJ700 (L700) outputs a disconnection signal when frequency command through analog input is lost.

Acceleration/Deceleration curve functions

The curve shape (five kinds, such as S-curve, etc.) can be chosen according to the application requirements.

Analog Command Holding Function (AHD)

Output frequency can be changed with UP/DOWN Function, or with an analog signal as reference value. The set frequency at power shutdown can be saved, too.

Pulse train input function

Pulse train input for Frequency reference or PID feed back signal, with SJ-FB (speed feed back card option).

Integrated Input Electric Power monitor

Input electric power (kW) and Integrated input electric power for monitoring energy saving.

Automatic Carrier Frequency Adjustment Function

The SJ700 detects motor current and automatically reduces carrier frequency according to the current.

The resolution of analog outputs (voltage, current) is improved to 10 bits.



STANDARD SPECIFICATIONS

SJ700 Series

● 3-phase 200V class

Model SJ700-		US Version	004LFUF2	007LFUF2	015LFUF2	022LFUF2	037LFUF2	055LFUF2	075LFUF2	110LFUF2	150LFUF2	185LFUF2	220LFUF2	300LFUF2	370LFUF2	450LFUF2	550LFUF2
		JP Version	004LFF2	007LFF2	015LFF2	022LFF2	037LFF2	055LFF2	075LFF2	110LFF2	150LFF2	185LFF2	220LFF2	300LFF2	370LFF2	450LFF2	550LFF2
Enclosure (*1)		IP20															
Applicable motor (4-pole, kW(HP)) (*2)		0.4(1/2)		0.75(1)	1.5(2)	2.2(3)	3.7(5)	5.5(7.5)	7.5(10)	11(15)	15(20)	18.5(25)	22(30)	30(40)	37(50)	45(60)	55(75)
Output Ratings	Rated capacity (kVA)	200V	1.0	1.7	2.5	3.6	5.7	8.3	11.0	15.9	22.1	26.3	32.9	41.9	50.2	63.0	76.2
		240V	1.2	2.0	3.1	4.3	6.8	9.9	13.3	19.1	26.6	31.5	39.4	50.2	60.2	75.6	91.4
	Rated output current (A)	3	5	7.5	10.5	16.5	24	32	46	64	76	95	121	145	182	220	
Overload capacity(output current)		150%,60sec., 200%,3sec.															
Rated output voltage (*3)		3-phase (3-wire) 200 to 240V (corresponding to input voltage)															
Input Rating	Rated input voltage (V)	3-phase 200 to 240V+10%, -15%, 50/60Hz±5%															
	Rated input current (A)	3.3	5.5	8.3	12	18	26	35	51	70	84	105	133	160	200	242	
Braking	Dynamic braking (Short-time) (*4)	Built-in BRD circuit (optional resistor)												External dynamic braking unit (option)			
	Minimum value of resistor (Ω)	50	50	35	35	35	16	10	10	7.5	7.5	5	-				
Vibration (*5)		5.9m/s ² (0.6G), 10-55Hz												2.9m/s ² (0.3G), 10-55Hz			
EMC filter		Built-in (EN61800-3 category C3)															
Zero-phase Reactor		Built-in															
Weight [kg] ([lbs.])		3.5(7.7)	3.5(7.7)	3.5(7.7)	3.5(7.7)	3.5(7.7)	6(13.2)	6(13.2)	6(13.2)	14(30.8)	14(30.8)	14(30.8)	22(48.4)	30(66)	30(66)	43(94.6)	

● 3-phase 400V class

Model SJ700-		European Version	007HFEF2	015HFEF2	022HFEF2	040HFEF2	055HFEF2	075HFEF2	110HFEF2	150HFEF2	185HFEF2	220HFEF2	300HFEF2	370HFEF2	450HFEF2	550HFEF2	
		US Version	007HFUF2	015HFUF2	022HFUF2	040HFUF2	055HFUF2	075HFUF2	110HFUF2	150HFUF2	185HFUF2	220HFUF2	300HFUF2	370HFUF2	450HFUF2	550HFUF2	
		JP Version	007HFF2	015HFF2	022HFF2	037HFF2	055HFF2	075HFF2	110HFF2	150HFF2	185HFF2	220HFF2	300HFF2	370HFF2	450HFF2	550HFF2	
Enclosure (*1)		IP20															
Applicable motor (4-pole, kW(HP)) (*2)		0.75(1)		1.5(2)	2.2(3)	3.7(5) 4.0(5)	5.5(7.5)	7.5(10)	11(15)	15(20)	18.5(25)	22(30)	30(40)	37(50)	45(60)	55(75)	
Output Ratings	Rated capacity (kVA)	400V	1.7	2.6	3.6	6.2	9.6	13.1	17.3	22.1	26.3	33.2	40.1	51.9	63.0	77.6	
		480V	2.0	3.1	4.4	7.4	11.6	15.7	20.7	26.6	31.5	39.9	48.2	62.3	75.6	93.1	
	Rated output current (A)	2.5	3.8	5.3	9.0	14	19	25	32	38	48	58	75	91	112		
Overload capacity(output current)		150%,60sec., 200%,3sec.															
Rated output voltage (*3)		3-phase (3-wire) 380 to 480V (corresponding to input voltage)															
Input Rating	Rated input voltage (V)	3-phase 380 to 480V +10%, -15%, 50/60Hz±5%															
	Rated input current (A)	2.8	4.2	5.8	9.9	17	23	30	35	42	53	64	83	100	123		
Braking	Dynamic braking (Short-time) (*4)	Built-in BRD circuit (optional resistor)												External dynamic braking unit (option)			
	Minimum value of resistor (Ω)	100	100	100	70	70	35	35	24	24	20	-					
Vibration (*5)		5.9m/s ² (0.6G), 10-55Hz												2.9m/s ² (0.3G), 10-55Hz			
EMC filter		Built-in (EN61800-3 category C3)															
Zero-phase Reactor		Built-in															
Weight [kg] ([lbs.])		3.5(7.7)	3.5(7.7)	3.5(7.7)	3.5(7.7)	6(13.2)	6(13.2)	6(13.2)	14(30.8)	14(30.8)	14(30.8)	22(48.4)	30(66)	30(66)	30(66)		

Model SJ700-		European Version	750HFEF2	900HFEF2	1100HFEF2	1320HFEF2	1850HFE2	2200HFE2	3150HFE2	4000HFE2
		US Version	750HFUF2	900HFUF2	1100HFUF2	1500HFUF2	1850HFU2	2200HFU2	3150HFU2	4000HFU2
		JP Version	750HFF2	900HFF2	1100HFF2	1320HFF2	1850HF2	2200HF2	3150HF2	4000HF2
Enclosure (*1)		IP00								
Applicable motor (4-pole, kW(HP)) (*2)		75(100)		90(125)	110(150)	132(150)	185(250)	220(300)	315(400)	400(550)
Output Ratings	Rated capacity (kVA)	400V	103.2	121.9	150.3	180.1	256	305	416	554
		480V	123.8	146.3	180.4	216.1	308	366	499	665
	Rated output current (A)	149	176	217	260	370	440	600	800	
Overload capacity(output current)		150%,60sec., 200%,0.5sec.			150%,60sec., 180%,0.5sec.					
Rated output voltage (*3)		3-phase (3-wire) 380 to 480V (corresponding to input voltage)								
Input Rating	Rated input voltage (V)	3-phase 380 to 480V +10%, -15%, 50/60Hz±5%								
	Rated input current (A)	164	194	239	286	389	455	630	840	
Braking	Dynamic braking (Short-time) (*4)	External dynamic braking unit (option)								
	Minimum value of resistor (Ω)	-								
Vibration (*5)		2.9m/s ² (0.3G), 10-55Hz				1.96m/s ² (0.2G), 10-55Hz				
EMC filter		Built-in (EN61800-3 category C3)				External Option				
Zero-phase Reactor		Built-in				External Option				
Weight [kg] ([lbs.])		60(132)	60(132)	80(176)	80(176)	140(308)	145(319)	210(462)	360(792)	

STANDARD SPECIFICATIONS

L700 Series

● 3-phase 200V class

Model L700-		110LFF	150LFF	185LFF	220LFF	300LFF	370LFF	450LFF	550LFF	750LFF	
Enclosure (*1)		IP20									
Applicable motor (4-pole, kW(HP)) (*2)		11(15)	15(20)	18.5(25)	22(30)	30(40)	37(50)	45(60)	55(75)	75(100)	
Output Ratings	Rated capacity (kVA)	200V	15.2	20.0	25.2	29.4	39.1	48.4	58.5	72.7	93.5
		240V	18.2	24.1	30.3	35.3	46.9	58.1	70.2	87.2	112.2
	Rated output current (A)		44	58	73	85	113	140	169	210	270
	Overload capacity(output current)		120%,60sec								
Rated output voltage (*3)		3-phase (3-wire) 200 to 240V (corresponding to input voltage)									
Input Rating	Rated input voltage (V)		3-phase 200 to 240V+10%, -15%, 50/60Hz±5%								
	Rated input current (A)		48	64	80	94	120	150	186	240	280
Braking	Dynamic braking (Short-time) (*4)		Built-in BRD circuit (optional resistor)				External dynamic braking unit (option)				
	Minimum value of resistor (Ω)		10	10	7.5	7.5	5	-			
Vibration (*5)		5.9m/s ² (0.6G), 10-55Hz					2.9m/s ² (0.3G), 10-55Hz				
EMC filter		Built-in (EN61800-3 category C3)									
Zero-phase Reactor		Built-in									
Weight [kg] (lbs.)		6(13.2)	6(13.2)	14(30.8)	14(30.8)	14(30.8)	22(48.4)	30(66)	30(66)	43(94.6)	

● 3-phase 400V class

Model L700-		110HFF	150HFF	185HFF	220HFF	300HFF	370HFF	450HFF	550HFF	750HFF	900HFF	1100HFF	1320HFF	1600HFF	
Enclosure (*1)		IP20									IP00				
Applicable motor (4-pole, kW(HP)) (*2)		11(15)	15(20)	18.5(25)	22(30)	30(40)	37(50)	45(60)	55(75)	75(100)	90(125)	110(150)	132(150)	160(220)	
Output Ratings	Rated capacity (kVA)	400V	15.2	20.0	25.6	29.7	39.4	48.4	58.8	72.7	93.5	110.8	135.0	159.3	200.9
		480V	18.2	24.1	30.7	35.7	47.3	58.1	70.6	87.2	112.2	133.0	162.1	191.2	241.1
	Rated output current (A)		22	29	37	43	57	70	85	105	135	160	195	230	290
	Overload capacity(output current)		120%,60sec												
Rated output voltage (*3)		3-phase (3-wire) 380 to 480V (corresponding to input voltage)													
Input Rating	Rated input voltage (V)		3-phase 380 to 480V +10%, -15%, 50/60Hz±5%												
	Rated input current (A)		24	32	41	47	63	77	94	116	149	176	199	253	300
Braking	Dynamic braking (Short-time) (*4)		Built-in BRD circuit (optional resistor)				External dynamic braking unit (option)								
	Minimum value of resistor (Ω)		35	35	24	24	20	-							
Vibration (*5)		5.9m/s ² (0.6G), 10-55Hz					2.9m/s ² (0.3G), 10-55Hz								
EMC filter		Built-in (EN61800-3 category C3)													
Zero-phase Reactor		Built-in													
Weight [kg] (lbs.)		6(13.2)	6(13.2)	14(30.8)	14(30.8)	14(30.8)	22(48.4)	30(66)	30(66)	30(66)	55(121)	55(121)	70(154)	70(154)	

*1: The protection method conforms to JEM 1030.

*2: The applicable motor refers to Hitachi standard 3-phase motor (4-pole). To use other motors, be sure to prevent the rated motor current (50Hz) from exceeding the rated output current of the inverter.

*3: The output voltage decreases as the main power supply voltage decreases except for the use of AVR function.

*4: Braking resistor is not integrated in the inverter. Please install optional braking resistor or dynamic braking unit when large braking torque is required.

*5: Conforms to the test method specified in JIS C 60068-2-6 : 2010 (IEC 60068-2-6 : 2007).

*6: To operate the motor beyond 50/60Hz, please consult with the motor manufacturer about the maximum allowable rotation speed.

*7: Storage temperature refers to the temperature in transportation.

*8: The frequency command is the maximum frequency at 9.8V for input voltage 0 to 10VDC, or at 19.6mA for input current 4 to 20mA. If this characteristic is not satisfactory for your application, contact your Hitachi representative.

Model Name Indication

SJ700 series

SJ700-055HFEF2

L700 series

L700-110LFF

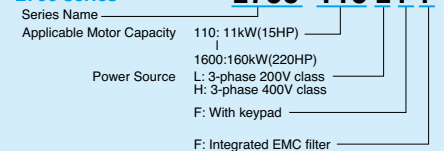
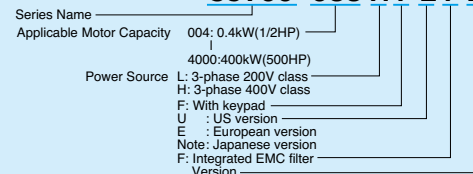

Model Configuration

● Available ○ Plan model

Applicable Motor kW (HP)		0.4 (1/2)	0.75 (1)	1.5 (2)	2.2 (3)	3.7 (5)	4.0 (5)	5.5 (7.5)	7.5 (10)	11 (15)	15 (20)	18.5 (25)	22 (30)	30 (40)	37 (50)	45 (60)	55 (75)	75 (100)	90 (125)	110 (150)	132 (175)	150 (200)	160 (220)	185 (250)	220 (300)	315 (400)	400 (550)		
SJ700	3-phase 200V	LFUF2	●	●	●	●	●	●	●	●	●	●	●	●	●	●	●	●	●	●	●	●	●	●	●	●	●	●	
		LFF2	●	●	●	●	●	●	●	●	●	●	●	●	●	●	●	●	●	●	●	○	○						
	3-phase 400V	HFEF2	●	●	●	●	●	●	●	●	●	●	●	●	●	●	●	●	●	●	●	●	●	●	●	●	●	●	●
		HFF2	●	●	●	●	●	●	●	●	●	●	●	●	●	●	●	●	●	●	●	●	●	●	●	●	●	●	●
L700	3-phase 200V									●	●	●	●	●	●	●	●	●	●	●	●	●	●	●	●	●	●	●	
	3-phase 400V									●	●	●	●	●	●	●	●	●	●	●	●	●	●	●	●	●	●	●	

SPECIFICATIONS

● General Specifications

Items		General Specifications	
Control	Control method	Line to line sine wave pulse-width modulation (PWM) control	
	Output frequency range (*6)	0.1-400.0Hz(400kW and over:0.1-120Hz)	
	Frequency accuracy	Digital: $\pm 0.01\%$ of the maximum frequency, Analog: $\pm 0.2\%$ ($25\pm 10^{\circ}\text{C}$)	
	Frequency resolution	Digital setting: 0.01Hz, Analog setting: (Maximum frequency)/4,000 (O terminal: 12bit 0-10V, O2 terminal: 12bit -10-+10V)	
	V/f characteristics	V/f optionally variable (30-400Hz of base frequency), V/f control (constant torque, reduced torque), Sensorless vector control, 0Hz domain sensorless vector control(*9), vector control (SJ-FB card option)(*9)	
	Speed fluctuation	$\pm 0.5\%$ (sensorless vector control)	
	Acceleration/deceleration time	0.01-3,600sec. (Linear/curve, accel./decel. selection), Two-stage accel./decel.	
	Starting Torque	SJ700 (Sensorless vector control): 200% at 0.3Hz/ 75 to 132kW :180% at 0.3Hz/185kW and over:150% at 0.3Hz L700 (Sensorless vector control): 150% at 0.5Hz/ 90kW and over:120% at 0.3Hz. SJ700 (0Hz domain with motor one frame size down):150% at around 0Hz/ 75kW and over: 130% at around 0Hz.	
Carrier frequency range	SJ700: 0.5-15.0kHz(185kW and over:0.5-3.0kHz)/L700: 0.5-12.0kHz(90kW and over:0.5-8.0kHz)		
DC braking	Performs at start: under set frequency at deceleration, via an external input (braking force, time, and operating frequency).		
Input signal	Frequency setting	Operator	Up and Down keys
		External signal*8	DC 0-10V, -10-+10V (input impedance 10k Ω), 4-20mA (input impedance 100 Ω)
		External port	Setting via RS485 communication
	Forward /reverse Start /stop	Operator	Start/stop commands (forward/reverse switching by parameter setting)
		External signal	Forward-operation start/stop commands (reverse-operation start/stop possible when relevant commands are assigned to intelligent input terminals)3-wire input possible (when relevant commands are assigned to control circuit terminals)
	Intelligent input terminals	External port	Setting via RS485 communication
		Terminals	8 terminals, NO/NC switchable, sink logic/source logic switchable
		Functions	Reverse operation (RV), Multi-speed 1 setting (CF1), Multi-speed 2 setting (CF2), Multi-speed 3 setting (CF3), Multi-speed 4 setting (CF4), Jogging (JG), external DC braking (DB), 2nd motor control (SET), 2-stage acceleration/deceleration (2CH), free-run stop (FRS), external trip (EXT), unattended start protection (USP), commercial power supply switching (CS), software lock (SFT), analog input switching (AT), 3rd motor control (SET3), reset (RS), starting by 3-wire input (STA), stopping by 3-wire input (STP), forward/reverse switching by 3-wire input (F/R), PID disable (PID), PID integration reset (PIDC), control gain switching (CAS), acceleration by remote control (UP), deceleration by remote control (DWN), data clearance by remote control (UDC), forcible operation (OPE), Multi-speed bit 1 (SF1), Multi-speed bit 2 (SF2), Multi-speed bit 3 (SF3), Multi-speed bit 4 (SF4), Multi-speed bit 5 (SF5), Multi-speed bit 6 (SF6), Multi-speed bit 7 (SF7), overload restriction selection (OLR), torque limit selection (enabling/disabling) (TL), torque limit 1 (TRQ1), torque limit 2 (TRQ2), P/Pi switching (PPI), braking confirmation (BOK)(*9), orientation (ORT)(*9), LAD cancellation (LAC), clearance of position deviation (PCLR)(*9), permission of 90° shift phase (STAT)(*9), trigger for frequency addition (A145) (ADD), forcible-terminal operation (F-TM), permission of torque command input (ATR)(*9), cumulative power clearance (KHC), servo-on (SON)(*9), pre-excitation (FOC)(*9), general-purpose input 1 (MI1), general-purpose input 2 (MI2), general-purpose input 3 (MI3), general-purpose input 4 (MI4), general-purpose input 5 (MI5), general-purpose input 6 (MI6), general-purpose input 7 (MI7), general-purpose input 8 (MI8), analog command holding (AHD), Multistage position settings selection 1 (CP1)(*9), Multistage position settings selection 2 (CP2)(*9), Multistage position settings selection 3 (CP3)(*9), Zero-return limit function (ORL)(*9), Zero-return trigger function (ORG)(*9), Forward drive stop (FOT)(*9), reverse drive stop (ROT)(*9), Speed / position switching (SPD)(*9), Pulse counter (PCNT), Pulse counter clear (PCC), Emergency stop (EMR) ,no assignment (no)
		Thermistor input	1 terminal (PTC characteristics)
		Terminals	5 open-collector output terminals, NO/NC switchable, sink logic/source logic switchable 1 relay (1c-contact) output terminal: NO/NC switchable
Output signal	Intelligent output terminals	Functions	Running (RUN), constant-speed reached (FA1), set frequency overreached (FA2), overload notice advance signal (1) (OL), output deviation for PID control (OD), alarm signal (AL), set frequency reached (FA3), over-torque (OTQ), instantaneous power failure (IP), undervoltage (UV), torque limited (TRQ), operation time over (RNT), plug-in time over (ONT), thermal alarm signal (THM), brake release (BRK)(*9), braking error (BER)(*9), 0Hz detection signal (ZS), speed deviation maximum (DSE)(*9), positioning completed (POK)(*9), set frequency overreached 2 (FA4), set frequency reached 2 (FA5), overload notice advance signal (2) (OL2), PID feedback comparison (FBV), communication line disconnection (NDC), logical operation result 1 (LOG1), logical operation result 2 (LOG2), logical operation result 3 (LOG3), logical operation result 4 (LOG4), logical operation result 5 (LOG5), logical operation result 6 (LOG6), capacitor life warning (WAC), cooling-fan speed drop (WAF), starting contact signal (FR), heat sink overheat warning (OHF), low-current indication signal (LOC), general-purpose output 1 (M01), general-purpose output 2 (M02), general-purpose output 3 (M03), general-purpose output 4 (M04), general-purpose output 5 (M05), general-purpose output 6 (M06), inverter ready (IRDY), forward rotation (FWR), reverse rotation (RVR), major failure (MJA), window comparator O (WCO), window comparator OI (WCOI), window comparator O2 (WCO2), alarm code 0 to 3 (AC0 to AC3)
		Monitor output terminals	Analog voltage output, analog current output, pulse-string output (e.g., A-F, D-F [n-fold, pulse output only], A, T, V, P)
	Monitoring on display	Output frequency, output current, output torque, frequency conversion data, trip history, input/output terminal status, electric power, and others	
Other functions	Free V/f setting (7 breakpoints), frequency upper/lower limit, jump (center) frequency, acceleration/deceleration according to characteristic curve, manual torque boost level/breakpoint, energy-saving operation, analog meter adjustment, start frequency setting, carrier frequency adjustment, electronic thermal function (available also for free setting), external start/end frequency/frequency rate, analog input selection, retry after trip, restart after instantaneous power failure, output of various signals, starting with reduced voltage, overload restriction, initial-value setting, automatic deceleration at power failure, AVR function, fuzzy acceleration/deceleration(*9), online/offline auto-tuning, high-torque multi-motor operation (sensorless vector control of two motors by one inverter)		
Protective functions	Overcurrent protection, overvoltage protection, undervoltage protection, electronic thermal protection, temperature error protection, instantaneous power failure protection, phase loss input protection, braking-resistor overload protection, ground-fault current detection at power-on, USP error, external trip, emergency stop trip, CT error, communication error, option board error, and others		
Environmental conditions	Ambient operating/storage temperature(*7)/ humidity	-10-50°C(*10) / -20-65°C / 20-90%RH (No condensation)	
	Location	Altitude 1,000m or less, indoors (no corrosive gases or dust)	
Options	Digital input expansion card	SJ-DG (4digits BCD, 16bits binary)	
	Feedback expansion card	SJ-FB (vector control loop speed sensor)	
	Network interface card	SJ-DN2(DeviceNet(TM)), SJ-PBT(PROFIBUS)	
	Others	EMI filters, input/output reactors, radio noise filters, braking resistors, braking units, LCR filter, communication cables	

*1: The protection method conforms to JEM 1030.

*2: The applicable motor refers to Hitachi standard 3-phase motor (4-pole).

To use other motors, be sure to prevent the rated motor current (50Hz) from exceeding the rated output current of the inverter.

*3: The output voltage decreases as the main power supply voltage decreases except for the use of AVR function.

*4: Braking resistor is not integrated in the inverter. Please install optional braking resistor or dynamic braking unit when large braking torque is required.

*5: Conforms to the test method specified in JIS C 60068-2-6:2010 (IEC 60068-2-6:2007).

*6: To operate the motor beyond 50/60Hz, please consult with the motor manufacturer about the maximum allowable rotation speed.

*7: Storage temperature refers to the temperature in transportation.

*8: The frequency command is the maximum frequency at 9.8V for input voltage 0 to 10VDC, or at 19.6mA for input current 4 to 20mA. If this characteristic is not satisfactory for your application, contact your Hitachi representative.

*9: L700 series: The function is not provided.

*10: L700 series is -10 to 40°C.

*11: Please be sure to connect DC reactor attached to 4000HF.

DIMENSIONS

- SJ700-004~037 LFUF2, LFF2
- SJ700-007~040HFEF2, HFUF2, 007~037HFF2

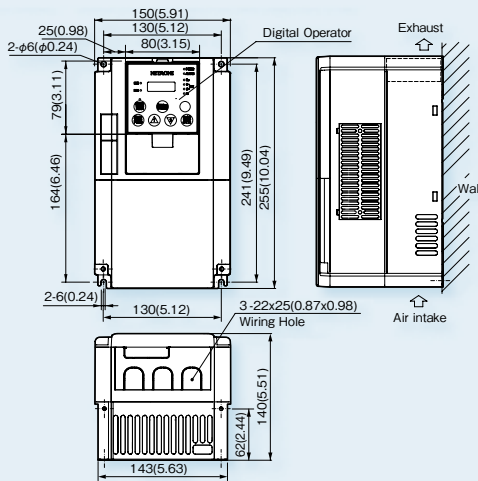

- SJ700-055~110 LFUF2,LFF2 /HFEF2, HFUF2,HFF2
- L700-110~150LFF/HFF

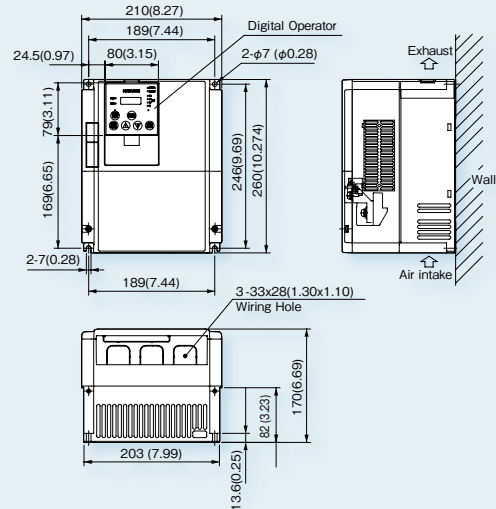

- SJ700-150~220 LFUF2,LFF2 /HFEF2, HFUF2,HFF2
- L700-185~300LFF/HFF

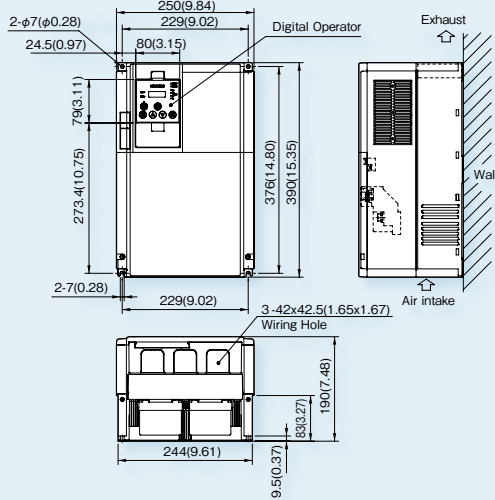

- SJ700-300 LFUF2,LFF2 /HFEF2, HFUF2, HFF2
- L700-370LFF/HFF

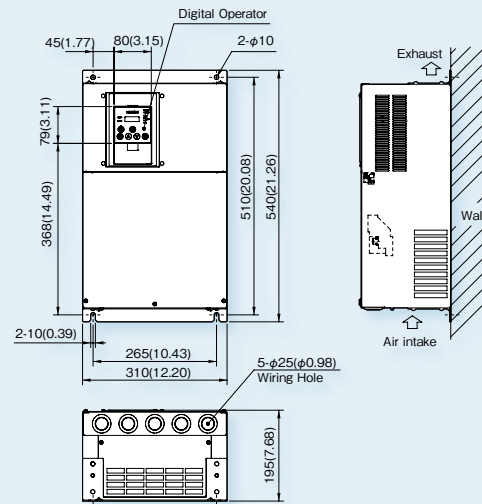

- SJ700-370~450 LFUF2,LFF2
- SJ700-370~550 HFEF2, HFUF2,HFF2
- L700-450~550LFF/450~750HFF

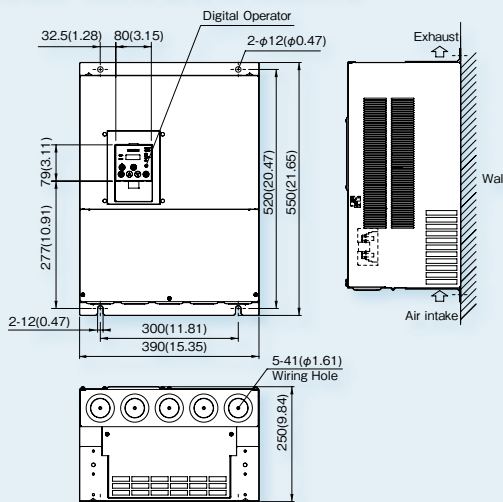

- SJ700-550 LFUF2,LFF2
- L700-750LFF

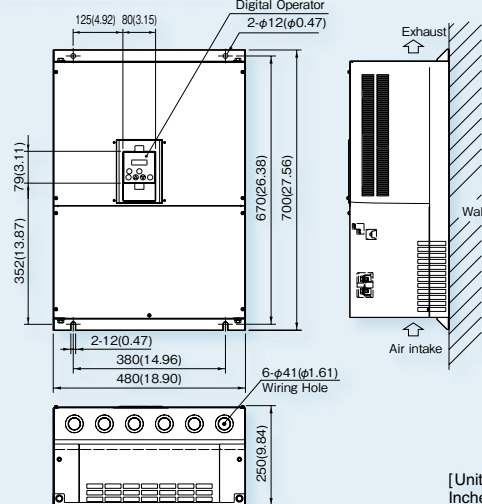

[Unit : mm (inch)]
Inches for reference only.

* Please refer to page 26 for detailed information about compatibility with SJ300.

DIMENSIONS

- SJ700-750, 900HFEF2, HFUF2, HFF2
- L700-900, 1100HFF

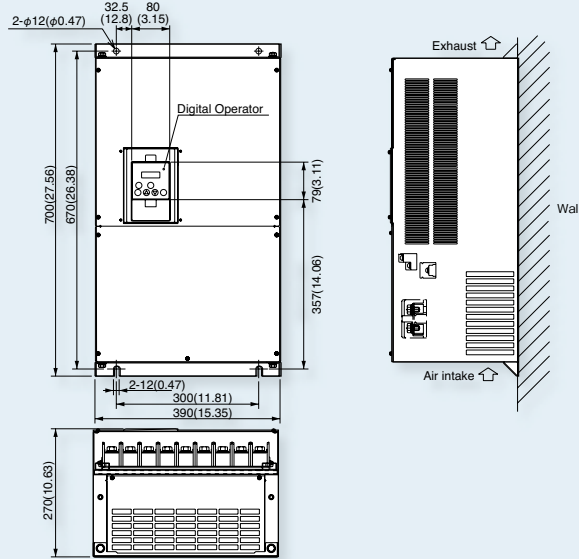

- SJ700-1100HFEF2, HFUF2, HFF2 / 1320HFEF2, HFF2, 1500HFUF2
- L700-1320, 1600HFF

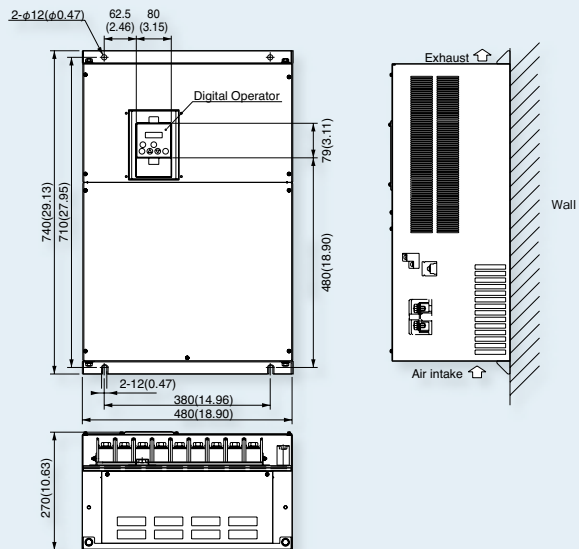

[Unit : mm (inch)]
Inches for reference only.

DIMENSIONS

● SJ700-1850,2200HFEF2,HFUF2,HFF2

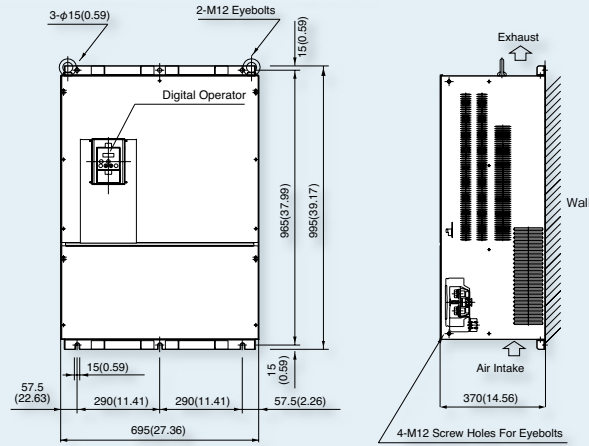

● SJ700-3150HFEF2,HFUF2,HFF2

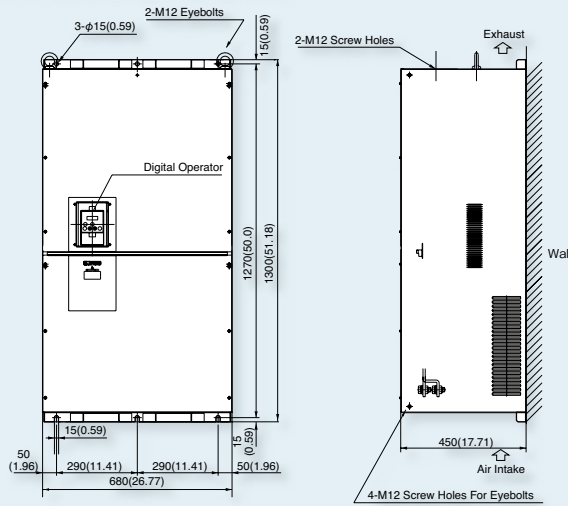

● SJ700-4000HFEF2,HFUF2,HFF2

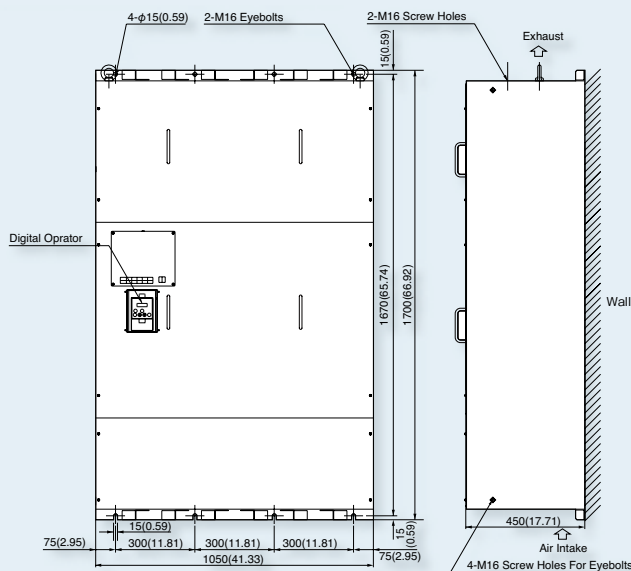

Attachment DC reactor(DCL-H-400)

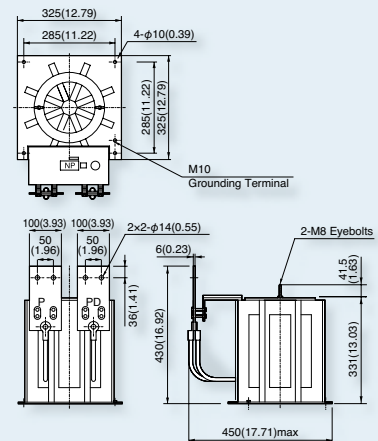

[Unit : mm (inch)]
Inches for reference only.

OPERATION and PROGRAMMING

SJ700 and L700 Series can be easily operated with the digital operator provided as standard. The digital operator can also be detached and can be used for remote-control. Operator with copy function (WOP) and digital operator with potentiometer are also available as options.

Parameter Display

Displays frequency, motor current, rotational speed of the motor, and an alarm code.

Monitor LEDs

Shows drive status.

RUN key enable LED

Lights up when the inverter is ready to respond to the RUN key.

RUN Key

Press to run the motor.

STOP/RESET Key

Press to stop the drive or reset an alarm.

Function Key

Press to set or monitor a parameter value.

Power LED

Lights when the power input to the drive is ON.

ALARM LED

Lights to indicate that the inverter has tripped.

Display Unit LEDs

Indicates the unit associated with the parameter display.

Store Key

Press to write the new value to the EEPROM.

Up/Down Keys

Press up or down to sequence through parameters and functions shown on the display, and increment/decrement values.



● Setting the output frequency

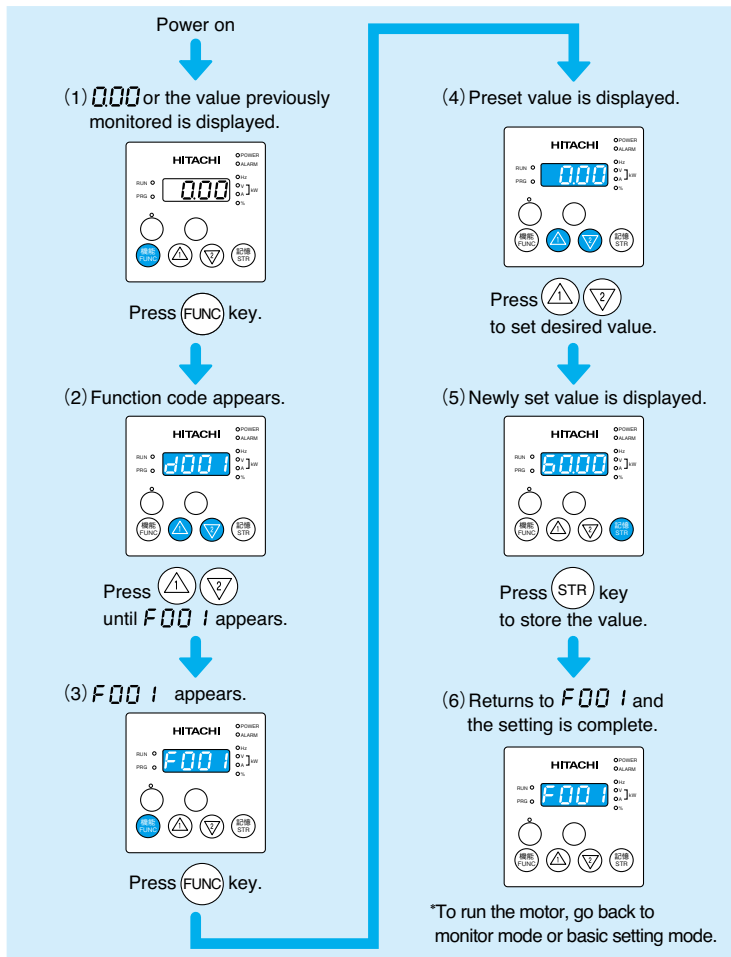

● The contents of a basic mode display.(default)

If a desired parameter is not displayed, check the setting of function "b037" (function code display restriction). To display all parameters, specify "00" for "b037".

No.	Display code	Item
1	d001 to d104	Monitor display
2	F001	Output frequency setting
3	F002	Acceleration (1) time setting
4	F003	Deceleration (1) time setting
5	F004	Operation direction setting
6	A001	Frequency source setting
7	A002	Run command source setting
8	A003	Base frequency setting
9	A004	Maximum frequency setting
10	A005	[AT] selection
11	A020	Multi-speed frequency setting
12	A021	Multi-speed 1 setting
13	A022	Multi-speed 2 setting
14	A023	Multi-speed 3 setting
15	A044	1st control method
16	A045	V/f gain setting
17	A085	Operation mode selection
18	b001	Selection of restart mode
19	b002	Allowable under-voltage power failure time
20	b008	Retry-after-trip selection
21	b011	Retry wait time after trip
22	b037	Function code display restriction
23	b083	Carrier frequency setting
24	b084	Initialization mode selection
25	b130	Selection of overvoltage suppression function
26	b131	Setting of overvoltage suppression level
27	C021	Setting of intelligent output terminal 11
28	C022	Setting of intelligent output terminal 12
29	C036	Alarm relay active state

TERMINALS

MAIN CIRCUIT TERMINALS

● Terminal Description

Terminal Symbol	Terminal Name	Terminal Symbol	Terminal Name
R(L1), S(L2), T(L3)	Main power supply input terminals	P(+), N(-)	External braking unit connection terminals
U(T1), V(T2), W(T3)	Inverter output terminals	⊕ (G)	Ground connection terminal
PD(+1), P(+)	DC reactor connection terminals	Ro(Ro), To(To)	Control power supply input terminals
P(+), RB(RB)	External braking resistor connection terminals		

● Screw Diameter and Terminal Width

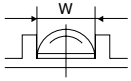

Model	Screw diameter	Ground Screw diameter	Terminal width (mm)
004~037LFF2,LFUF2/007~037HFF2,HFEF2,HFUF2	M4	M4	13
055,075LFF2,LFUF2/HFF2,HFEF2,HFUF2	M5	M5	18
110LFF2,LFUF2/HFF2,HFEF2,HFUF2	M6	M6	18
150,185LFF2,LFUF2/150-300HFF2,HFEF2,HFUF2	M6	M6	23
220,300LFF2,LFUF2	M8	M6	23
370,450LFF2,LFUF2/370-550HFF2,HFEF2,HFUF2	M8	M8	29
550LFF2,LFUF2	M10	M8	40
750,900HFF2,HFEF2,HFUF2	M10	M8	29
1100HFF2,HFEF2,HFUF2/1320HFF2,HFEF2/1500HFUF2	M10	M8	40
1850,2200HF2,HFE2,HFU2	M16	M12	51
3150HF2,HFE2,HFU2	M16	M12	45
4000HF2,HFE2,HFU2	M12	M12	50
RoTo terminals (All models)	M4	-	9

● Terminal Arrangement

■ SJ700-004-037LFUF2, LFF2/007-037HFEF2, HFUF2, HFF2

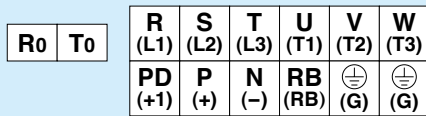

■ SJ700-1850, 2200HFEF2, HFUF2, HFF2

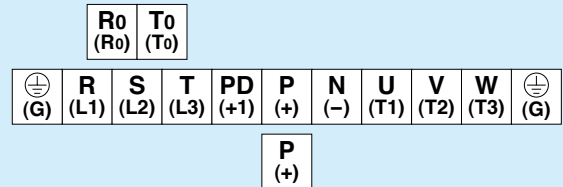

■ SJ700-055-220LFUF2, LFF2, HFEF2, HFUF2, HFF2 ■ L700-110-300LFF/HFF

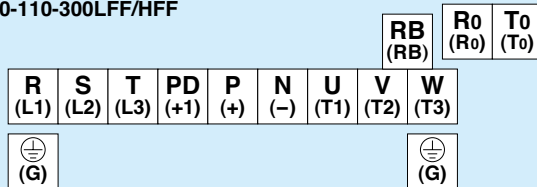

■ SJ700-3150HFEF2, HFUF2, HFF2

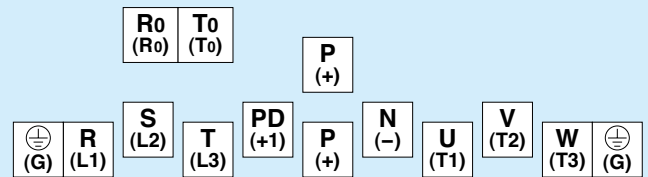

■ SJ700-300-370LFUF2, LFF2, 300~550HFEF2, HFUF2, HFF2 ■ L700-370-450LFF/370-750HFF

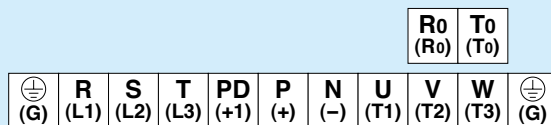

■ SJ700-4000HFEF2, HFUF2, HFF2

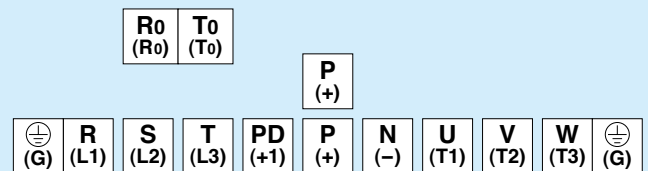

■ SJ700-450-550LFUF2, LFF2, 750-1100HFEF2, HFUF2, HFF2 ■ L700-550-750LFF/900-1600HFF

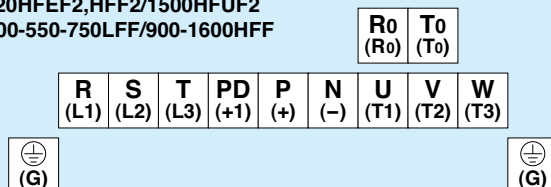

TERMINALS

CONTROL CIRCUIT TERMINALS

● Terminal Description

		Symbol	Name	Explanation of Terminals	Ratings		
Analog	Power Supply	L	Common Terminal for Analog Power Source	Common terminal for H, O, O2, OI, AM, and AMI. Do not ground.	-		
		H	Power Source for Frequency Setting	Power supply for frequency command input	DC 10V, 20mA max.		
	Frequency Setting	O	Frequency Command Terminal	Maximum frequency is attained at DC 10V in DC 0-10V range. Set the voltage at A014 to command maximum frequency below DC 10V.	Input impedance: 10kΩ, Allowable input voltage range: DC -0.3~+12V		
		O2	Frequency Command Extra Terminal	O2 signal is added to the frequency command of O or OI in DC 0-±10V range. By changing configuration, frequency command can be input also at O2 terminal.	Input impedance:10kΩ, Allowable input voltage range: DC 0-±12V		
		OI	Frequency Command Terminal	Maximum frequency is attained at DC 20mA in DC 4-20mA range. When the intelligent terminal configured as AT is on, OI signal is enabled.	Input impedance: 100Ω, Allowable input voltage range: DC 0-24mA		
	Monitor Output	AM	Analog Output Monitor (Voltage)	Selection of one function from: Output frequency, output current, torque, output voltage, input power, electronic thermal load ratio, and LAD frequency.	DC 0-10V, 2mA max.		
AMI		Analog Output Monitor (Current)	DC 4-20mA, 250Ω max.				
Digital	Monitor Output	FM	Digital Monitor (Voltage)	[DC0-10V output (PWM output)] Selection of one function from: Output frequency, output current, torque, output voltage, input power, electronic thermal load ratio, and LAD frequency. [Digital pulse output (Pulse voltage DC 0/10V)] Outputs the value of output frequency as digital pulse (duty 50%)	Digital output frequency range: 0-3.6kHz, 1.2mA max.		
	Power Supply	P24	Power Terminal for Interface	Internal power supply for input terminals. In the case of source type logic, common terminal for contact input terminals.	DC 24V, 100mA max.		
		CM1	Common Terminal for Interface	Common terminal for P24, TH, and FM. In the case of sink type logic, common terminal for contact input terminals. Do not ground.	-		
	Contact Input	Run Command	FW	Forward Command Input	The motor runs forward when FW terminal is ON, and stops when FW is OFF.	[Input ON condition] Voltage between each terminal and PLC: DC 18V min. [Input OFF condition] Voltage between each terminal and PLC: DC 3V max. Input impedance between each terminal and PLC: 4.7Ω Allowable maximum voltage between each terminal and PLC: DC 27V	
		Functions	1 2 3 4 5 6 7 8	Intelligent Input Terminals	Assign 8 functions to terminals. (Refer to the standard specifications for the functions.)		
			Common Terminal	PLC	Common Terminal for Intelligent Input Terminals, Common Terminal for External Power Supply for PLCs, etc.		Select sink or source logic with the short-circuit bar on the control terminals. Sink logic: Short P24 to PLC / Source logic: Short CM1 to PLC. When applying external power source, remove the short-circuit bar and connect PLC terminal to the external device.
	Open Collector Output	State	11 12 13 14 15	Intelligent Output Terminals	Assign 5 functions to open collector outputs. When the alarm code is selected at C062, terminal 11-13 or 11-14 are reserved for error codes of inverter trip. (Refer to the standard specifications for the functions.) Both sink and source logic are always applicable between each terminal and CM1.	Decrease in voltage between each terminal and CM2: 4V max. during ON Allowable maximum voltage: DC 27V Allowable maximum current: 50mA	
			CM2	Common Terminal for Intelligent Output Terminals	Common terminal for intelligent output terminal 11-15.		
	Analog	Analog Input	Sensor	TH	Thermistor Input Terminals	The inverter trips when the external thermistor detects abnormal temperature. Common terminal is CM1. [Recommended thermistor characteristics] Allowable rated power: 100mW or over. Impedance in the case of abnormal temperature: 3kΩ Note: Thermal protection level can be set between 0 and 9999Ω.	Allowable input voltage range
	Digital	Relay Output	State/Alarm	AL0 AL1 AL2	Alarm Output Terminals	In default setting, an alarm is activated when inverter output is turned off by a protective function. Maximum capacity of relays AL1-AL0: AC 250V, 2A(R load)/0.2A(L load) DC 30V, 8A(R load)/0.6A(L load) AL2-AL0: AC 250V, 1A(R load)/0.2A(L load) DC 30V, 1A(R load)/0.2A(L load) Minimum capacity of relays AL1-AL0, AL2-AL0: AC100V, 10mA DC5V, 100mA	

● Terminal Arrangement

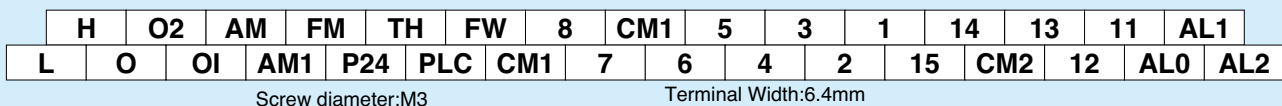

FUNCTION LIST

MONITORING FUNCTIONS and MAIN PROFILE PARAMETERS

[O= Allowed X= Not permitted]

Code	Function Name	Monitored data or setting	Default Setting				Setting during operation (allowed or not)	Change during operation (allowed or not)						
			SJ700			L700								
			-FE(CE)	-FU(UL)	-F(JP)									
d001	Output frequency monitor	0.00 to 99.99, 100.0 to 400.0 (Hz)	-	-	-	-	○	-						
d002	Output current monitor	0.0 to 999.9, 1000 to 9999 (A)	-	-	-	-	-	-						
d003	Rotation direction monitoring	F (forward rotation), o (stopped), r (reverse rotation)	-	-	-	-	-	-						
d004	Process variable (PV), PID feedback monitor	0.00 to 99.99, 100.0 to 999.9, 1000. to 9999. 1000 to 9999 (10000 to 99900), 100 to 999 (10000 to 999000)	-	-	-	-	-	-						
d005	Intelligent input terminal status	<table border="0"> <tr> <td>FW</td> <td>ON</td> <td>(Example) FW, 7, 2, 1 : ON</td> </tr> <tr> <td>OFF</td> <td>OFF</td> <td>8, 6, 5, 4, 3 : OFF</td> </tr> </table>	FW	ON	(Example) FW, 7, 2, 1 : ON	OFF	OFF	8, 6, 5, 4, 3 : OFF	-	-	-	-	-	-
FW	ON	(Example) FW, 7, 2, 1 : ON												
OFF	OFF	8, 6, 5, 4, 3 : OFF												
d006	Intelligent output terminal status	<table border="0"> <tr> <td>AL</td> <td>ON</td> <td>(Example) 12, 11 : ON</td> </tr> <tr> <td>OFF</td> <td>OFF</td> <td>AL, 15, 14, 13 : OFF</td> </tr> </table>	AL	ON	(Example) 12, 11 : ON	OFF	OFF	AL, 15, 14, 13 : OFF	-	-	-	-	-	-
AL	ON	(Example) 12, 11 : ON												
OFF	OFF	AL, 15, 14, 13 : OFF												
d007	Scaled output frequency monitoring	0.00 to 99.99, 100.0 to 999.9, 1000. to 9999., 1000 to 3996 (10000 to 39960)	-	-	-	-	○	-						
d008	Actual-frequency monitoring	-400. to -100., -99.9 to 0.00 to 99.99, 100.0 to 400.0 (Hz)	-	-	-	X	-	-						
d009	Torque command monitoring	0. to +200. (%)	-	-	-	X	-	-						
d010	Torque bias monitoring	-200. to +200. (%)	-	-	-	X	-	-						
d012	Torque monitoring	-200. to +200. (%)	-	-	-	-	-	-						
d013	Output voltage monitoring	0.0 to 600.0 (V)	-	-	-	-	-	-						
d014	Power monitoring	0.0 to 999.9 (kW)	-	-	-	-	-	-						
d015	Cumulative power monitoring	0.0 to 999.9, 1000. to 9999., 1000 to 9999 (10000 to 99900), 100 to 999 (100000 to 999000)	-	-	-	-	-	-						
d016	Cumulative operation RUN time monitoring	0. to 9999., 1000 to 9999 (10000 to 99900), 100 to 999 (10000 to 999000) (hr)	-	-	-	-	-	-						
d017	Cumulative power-on time monitoring	0. to 9999., 1000 to 9999 (10000 to 99900), 100 to 999 (10000 to 999000) (hr)	-	-	-	-	-	-						
d018	Heat sink temperature monitoring	-020. to 200.0 (°C)	-	-	-	-	-	-						
d019	Motor temperature monitoring	-020. to 200.0 (°C)	-	-	-	-	-	-						
d022	Life-check monitoring	<table border="0"> <tr> <td>ON</td> <td>1: Capacitor on main circuit board</td> </tr> <tr> <td>OFF</td> <td>2: Cooling-fan speed drop</td> </tr> </table>	ON	1: Capacitor on main circuit board	OFF	2: Cooling-fan speed drop	-	-	-	-	-	-		
ON	1: Capacitor on main circuit board													
OFF	2: Cooling-fan speed drop													
d023	Program counter	0 to 1024	-	-	-	-	-	-						
d024	Program number monitoring	0000 to 9999	-	-	-	-	-	-						
d025	User monitor 0	-2147483647 to 2147483647 (upper 4 digits including "-")	-	-	-	-	-	-						
d026	User monitor 1	-2147483647 to 2147483647 (upper 4 digits including "-")	-	-	-	-	-	-						
d027	User monitor 2	-2147483647 to 2147483647 (upper 4 digits including "-")	-	-	-	-	-	-						
d028	Pulse counter	0 to 2147483647 (upper 4 digits)	-	-	-	-	-	-						
d029	Position setting monitor	-1073741823 to 1073741823 (upper 4 digits including "-")	-	-	-	X	-	-						
d030	Position feedback monitor	-1073741823 to 1073741823 (upper 4 digits including "-")	-	-	-	X	-	-						
d080	Trip Counter	0. to 9999., 1000 to 6553 (10000 to 65530) (times)	-	-	-	-	-	-						
d081	Trip monitoring 1-6	Factor, frequency (Hz), current (A), voltage across P-N (V), running time (hours), power-on time (hours)	-	-	-	-	-	-						
d086														
d090	Programming error monitoring	Warning code	-	-	-	-	-	-						
d102	DC voltage monitoring	0.0 to 999.9 (V)	-	-	-	-	-	-						
d103	BRD load factor monitoring	0.0 to 100.0 (%)	-	-	-	-	-	-						
d104	Electronic thermal overload monitoring	0.0 to 100.0 (%)	-	-	-	-	-	-						
F001	Output frequency setting	0.0, "start frequency" to "maximum frequency" (or maximum frequency, 2nd/3rd motors) (Hz) 0.0 to 100.0 (when PID function is enabled)	0.00	0.00	0.00	0.00	○	○						
F002	Acceleration (1) time setting	0.01 to 99.99, 100.0 to 999.9, 1000. to 3600. (s)	30.00	30.00	30.00	30.00	○	○						
F202	Acceleration (1) time setting, 2nd motor	0.01 to 99.99, 100.0 to 999.9, 1000. to 3600. (s)	30.00	30.00	30.00	30.00	○	○						
F302	Acceleration (1) time setting, 3rd motor	0.01 to 99.99, 100.0 to 999.9, 1000. to 3600. (s)	30.00	30.00	30.00	30.00	○	○						
F003	Deceleration (1) time setting	0.01 to 99.99, 100.0 to 999.9, 1000. to 3600. (s)	30.00	30.00	30.00	30.00	○	○						
F203	Deceleration time setting, 2nd motor	0.01 to 99.99, 100.0 to 999.9, 1000. to 3600. (s)	30.00	30.00	30.00	30.00	○	○						
F303	Deceleration time setting, 3rd motor	0.01 to 99.99, 100.0 to 999.9, 1000. to 3600. (s)	30.00	30.00	30.00	30.00	○	○						
F004	Keypad Run key routing	00 (forward rotation), 01 (reverse rotation)	00	00	00	00	X	X						
A---	A Group: Standard functions													
b---	b Group: Fine tuning functions													
C---	C Group: Intelligent terminal functions													
H---	H Group: Motor constants functions													
P---	P Group: Expansion card functions													
U---	U Group: User-selectable menu functions													

A GROUP: STANDARD FUNCTIONS

[O= Allowed X= Not permitted]

Code	Function Name	Monitored data or setting	Default Setting				Setting during operation (allowed or not)	Change during operation (allowed or not)
			SJ700			L700		
			-FE(CE)	-FU(UL)	-F(JP)			
A001	Frequency source setting	00 (keypad potentiometer) (*1), 01 (control circuit terminal block), 02 (digital operator), 03 (RS485), 04 (option 1), 05 (option 2), 06 (pulse-string input), 07 (easy sequence), 10 (operation function result)	01	01	02	02	X	X
A002	Run command source setting	01 (control circuit terminal block), 02 (digital operator), 03 (RS485), 04 (option 1), 05 (option 2)	01	01	02	02	X	X
A003	Base frequency setting	30. to "maximum frequency" (Hz)	50.	60.	60.	60.	X	X
A203	Base frequency setting, 2nd motor	30. to "maximum frequency, 2nd motor" (Hz)	50.	60.	60.	60.	X	X
A303	Base frequency setting, 3rd motor	30. to "maximum frequency, 3rd motor" (Hz)	50.	60.	60.	60.	X	X
A004	Maximum frequency setting	30. to 400. (Hz)	50.	60.	60.	60.	X	X
A204	Maximum frequency setting, 2nd motor	30. to 400. (Hz)	50.	60.	60.	60.	X	X
A304	Maximum frequency setting, 3rd motor	30. to 400. (Hz)	50.	60.	60.	60.	X	X
A005	[AT] selection	00 (switching between O and OI terminals), 01 (switching between O and O2 terminals), 02 (switching between O terminal and keypad potentiometer) (*1), 03 (switching between OI terminal and keypad potentiometer) (*1), 04 (switching between O2 and keypad potentiometer) (*1)	00	00	00	00	X	X
A006	[O2] selection	00 (single), 01 (auxiliary frequency input via O and OI terminals) (nonreversible), 02 (auxiliary frequency input via O and OI terminals) (reversible), 03 (disabling O2 terminal)	03	03	03	03	X	X

*1 This setting is valid only when the OPE-SR is connected.

Code	Function Name	Monitored data or setting	Default Setting				Setting during operation (allowed or not)	Change during operation (allowed or not)	
			SJ700			L700			
			-FE(CE)	-FU(UL)	-F(JP)				
Analog input and others	A011	O-L input active range start frequency	0.00 to 99.99, 100.0 to 400.0 (Hz)				0.00	X	O
	A012	O-L input active range end frequency	0.00 to 99.99, 100.0 to 400.0 (Hz)				0.00	X	O
	A013	O-L input active range start voltage	0. to "[O]-[L] input active range end voltage" (%)				0.	X	O
	A014	O-L input active range end voltage	"[O]-[L] input active range start voltage" to 100. (%)				100.	X	O
	A015	O-L input active range start frequency selection	00 (external start frequency), 01 (0 Hz)				01	X	O
	A016	External frequency filter time constant	1. to 30. or 31. (500 ms filter ±0.1 Hz with hysteresis)				31.	X	O
	A017	Easy sequence function selection	00 (disabling), 01 (enabling)				00	X	X
Multispeed operation and Jogging	A019	Multispeed operation selection	00 (binary: 16 speeds selectable with 4 terminals), 01 (bit: 8 speeds selectable with 7 terminals)				00	X	X
	A020	Multispeed frequency setting	0.0 or "start frequency" to "maximum frequency" (Hz)				0.00	O	O
	A220	Multispeed frequency setting, 2nd motor	0.0 or "start frequency" to "maximum frequency, 2nd motor" (Hz)				0.00	O	O
	A320	Multispeed frequency setting, 3rd motor	0.0 or "start frequency" to "maximum frequency, 3rd motor" (Hz)				0.00	O	O
	A021	Multispeed 1-15 setting	0.0 or "start frequency" to "n-th maximum frequency" (Hz)				0.00	O	O
	A035								
	A038	Jog frequency setting	"Start frequency" to 9.99 (Hz)				1.00	O	O
A039	Jog stop mode	00 (free-running after jogging stops [disabled during operation]), 01 (deceleration and stop after jogging stops [disabled during operation]), 02 (DC braking after jogging stops [disabled during operation]), 03 (free-running after jogging stops [enabled during operation]), 04 (deceleration and stop after jogging stops [enabled during operation]), 05 (DC braking after jogging stops [enabled during operation])				00	X	O	
V/f Characteristic	A041	Torque boost method selection	00(Manual torque boost) / 01(Automatic torque boost)				00	X	X
	A241	Torque boost method selection, 2nd motor	00(Manual torque boost) / 01(Automatic torque boost)				00	X	X
	A042	Manual torque boost value	0.0 to 20.0 (%)				1.0	O	O
	A242	Manual torque boost value, 2nd motor	0.0 to 20.0 (%)				1.0	O	O
	A342	Manual torque boost value, 3rd motor	0.0 to 20.0 (%)				1.0	O	O
	A043	Manual torque boost frequency adjustment	0.0 to 50.0 (%)				5.0	O	O
	A243	Manual torque boost frequency adjustment, 2nd motor	0.0 to 50.0 (%)				5.0	O	O
	A343	Manual torque boost frequency adjustment, 3rd motor	0.0 to 50.0 (%)				5.0	O	O
	A044	V/F characteristic curve selection, 1st motor	00 (VC), 01 (VP), 02 (free V/f), 03 (sensorless vector control), 04 (0Hz-range sensorless vector)(*1), 05 (vector with sensor)(*1)				00	X	X
	A244	V/F characteristic curve selection, 2nd motor	00 (VC), 01 (VP), 02 (free V/f), 03 (sensorless vector control), 04 (0Hz-range sensorless vector)(*1)				00	X	X
	A344	V/F characteristic curve selection, 3rd motor	00(VC), 01(VP)				00	X	X
	A045	V/f gain setting	20. to 100. (%)				100.	O	O
	A046	Voltage compensation gain setting for automatic torque boost, 1st motor	0. to 255.				100.	O	O
	A246	Voltage compensation gain setting for automatic torque boost, 2nd motor	0. to 255.				100.	O	O
A047	Slippage compensation gain setting for automatic torque boost, 1st motor	0. to 255.				100.	O	O	
A247	Slippage compensation gain setting for automatic torque boost, 2nd motor	0. to 255.				100.	O	O	
DC Braking	A051	DC braking enable	00 (disabling), 01 (enabling), 02 (set frequency only)				00	X	O
	A052	DC braking frequency setting	0.00 to 99.99, 100.0 to 400.0 (Hz)				0.50	X	O
	A053	DC braking wait time	0.0 to 5.0 (s)				0.0	X	O
	A054	DC braking force during deceleration	SJ700: 0. to 100. (%) <75 to 132kW:0. to 80./185kW and over:0. to 35.> L700: 0. to 70. (%) <90kW and over:0. to 50.>				0	X	O
	A055	DC braking time for deceleration	0.0 to 60.0 (s)				0.0	X	O
	A056	DC braking/edge or level detection for [DB] input	00 (edge operation), 01 (level operation)				01	X	O
	A057	DC braking force for starting	SJ700: 0. to 100. (%) <75 to 132kW:0. to 80./185kW and over:0. to 35.> L700: 0. to 70. (%) <90kW and over:0. to 50.>				0.	X	O
	A058	DC braking time for starting	0.0 to 60.0(s)				0.0	X	O
	A059	DC braking carrier frequency setting	SJ700: 0.5 to 15.0(kHz) <75 to 132kW:0.5 to 10.0/185kW and over:0.5 to 3.0> L700: 0.5 to 12.0 (kHz) <90kW and over:0.5 to 8.0>				5.0	X	X
Frequency Upper/Lower Limit and Jump Frequency	A061	Frequency upper limit setting	0.00 or "1st minimum frequency limit" to "maximum frequency" (Hz)				0.00	X	O
	A261	Frequency upper limit setting, 2nd motor	0.00 or "2nd minimum frequency limit" to "maximum frequency, 2nd motor" (Hz)				0.00	X	O
	A062	Frequency lower limit setting	0.00 or "start frequency" to "maximum frequency limit" (Hz)				0.00	X	O
	A262	Frequency lower limit setting, 2nd motor	0.00 or "start frequency" to "maximum frequency, 2nd motor limit" (Hz)				0.00	X	O
	A063	Jump (center) frequency setting 1	0.00 to 99.99, 100.0 to 400.0 (Hz)				0.00	X	O
	A064	Jump (hysteresis) frequency width setting 1	0.00 to 10.00 (Hz)				0.50	X	O
	A065	Jump (center) frequency setting 2	0.00 to 99.99, 100.0 to 400.0 (Hz)				0.00	X	O
	A066	Jump (hysteresis) frequency width setting 2	0.00 to 10.00 (Hz)				0.50	X	O
	A067	Jump (center) frequency setting 3	0.00 to 99.99, 100.0 to 400.0 (Hz)				0.00	X	O
	A068	Jump (hysteresis) frequency width setting 3	0.00 to 10.00 (Hz)				0.50	X	O
	A069	Acceleration stop time frequency setting	0.00 to 99.99, 100.0 to 400.0 (Hz)				0.00	X	O
A070	Acceleration stop time frequency setting	0.0 to 60.0 (s)				0.0	X	O	
PID Control	A071	PID function enable	00 (disabling), 01 (enabling), 02 (enabling inverted-data output)				00	X	O
	A072	PID proportional gain	0.2 to 5.0				1.0	O	O
	A073	PID integral time constant	0.0 to 999.9, 1000. to 3600.0 (s)				1.0	O	O
	A074	PID derivative gain	0.00 to 99.99, 100.0 (s)				0.00	O	O
	A075	PV scale conversion	0.01 to 99.99				1.00	X	O
	A076	PV source setting	00 (input via OI), 01 (input via O), 02 (external communication), 03 (pulse-string frequency input), 10 (operation result output)				00	X	O
	A077	Output of inverted PID deviation	00(OFF), 01 (ON)				00	X	O
	A078	PID variation range	0.0 to 100.0 (%)				0.0	X	O
AVR	A081	AVR function select	00 (always on), 01 (always off), 02 (off during deceleration)				00	X	X
	A082	AVR voltage select	200 V class: 200, 215, 220, 230, 240 (V) 400 V class: 380, 400, 415, 440, 460, 480 (V)				230/400	X	X
	A085	Operation mode selection	00(Normal operation)/ 01(Energy-saving operation)/ 02(Fuzzy operation)(*1)				00	X	X
	A086	Energy saving mode tuning	0.1 to 100.0				50.0	O	O
	A092	Acceleration (2) time setting	0.01 to 99.99, 100.0 to 999.9, 1000. to 3600. (s)				15.00	O	O
	A292	Acceleration (2) time setting, 2nd motor	0.01 to 99.99, 100.0 to 999.9, 1000. to 3600. (s)				15.00	O	O
	A392	Acceleration (2) time setting, 3rd motor	0.01 to 99.99, 100.0 to 999.9, 1000. to 3600. (s)				15.00	O	O
Operation Mode and acceleration/ deceleration function	A093	Deceleration (2) time setting	0.01 to 99.99, 100.0 to 999.9, 1000. to 3600. (s)				15.00	O	O
	A293	Deceleration (2) time setting, 2nd motor	0.01 to 99.99, 100.0 to 999.9, 1000. to 3600. (s)				15.00	O	O
	A393	Deceleration (2) time setting, 3rd motor	0.01 to 99.99, 100.0 to 999.9, 1000. to 3600. (s)				15.00	O	O

*1 L700 series: The function is not provided.

Code	Function Name	Monitored data or setting	Default Setting				Setting during operation (allowed or not)	Change during operation (allowed or not)	
			SJ700			L700			
			-FE(CE)	-FU(UL)	-F(JP)				
External frequency adjustment	A094	Select method to switch to Acc2/Dec2 profile	00 (switching by 2CH terminal), 01 (switching by setting), 02 (switching only when rotation is reversed)	00	00	00	00	×	×
	A294	Select method to switch to Acc2/Dec2, 2nd motor	00 (switching by 2CH terminal), 01 (switching by setting), 02 (switching only when rotation is reversed)	00	00	00	00	×	×
	A095	Acc1 to Acc2 frequency transition point	0.00 to 99.99, 100.0 to 400.0 (Hz)	0.00	0.00	0.00	0.00	×	×
	A295	Acc1 to Acc2 frequency transition point, 2nd motor	0.00 to 99.99, 100.0 to 400.0 (Hz)	0.00	0.00	0.00	0.00	×	×
	A096	Dec1 to Dec2 frequency transition point	0.00 to 99.99, 100.0 to 400.0 (Hz)	0.00	0.00	0.00	0.00	×	×
	A296	Dec1 to Dec2 frequency transition point, 2nd motor	0.00 to 99.99, 100.0 to 400.0 (Hz)	0.00	0.00	0.00	0.00	×	×
	A097	Acceleration curve selection	00 (linear), 01 (S curve), 02 (U curve), 03 (inverted-U curve), 04 (EL-S curve)	00	00	00	00	×	×
	A098	Deceleration curve selection	00 (linear), 01 (S curve), 02 (U curve), 03 (inverted-U curve), 04 (EL-S curve)	00	00	00	00	×	×
	A101	OL-L input active range start frequency	0.00 to 99.99, 100.0 to 400.0 (Hz)	0.00	0.00	0.00	0.00	×	×
	A102	OL-L input active range end frequency	0.00 to 99.99, 100.0 to 400.0 (Hz)	0.00	0.00	0.00	0.00	×	○
	A103	OL-L input active range start current	0. to "[O]-[L] input active range end current" (%)	20.	20.	20.	20.	×	○
	A104	OL-L input active range end current	"[O]-[L] input active range start current" to 100. (%)	100.	100.	100.	100.	×	○
	A105	OL-L input start frequency enable	00 (external start frequency), 1 (0 Hz)	00	00	00	00	×	○
	A111	O2-L input active range start frequency	-400. to -100., -99.9 to 0.00 to 99.99, 100.0 to 400.0 (Hz)	0.00	0.00	0.00	0.00	×	○
A112	O2-L input active range end frequency	-400. to -100., -99.9 to 0.00 to 99.99, 100.0 to 400.0 (Hz)	0.00	0.00	0.00	0.00	×	○	
A113	O2-L input active range start voltage	-100. to O2 end-frequency rate (%)	-100.	-100.	-100.	-100.	×	○	
A114	O2-L input active range end voltage	"O2 start-frequency rate" to 100. (%)	100.	100.	100.	100.	×	○	
Acceleration and deceleration	A131	Acceleration curve constants setting	01 (smallest swelling) to 10 (largest swelling)	02	02	02	02	×	○
	A132	Deceleration curve constants setting	01 (smallest swelling) to 10 (largest swelling)	02	02	02	02	×	○
Operation-target frequency	A141	Operation-target frequency selection 1	00 (digital operator), 01 (keypad potentiometer), 02 (input via O), 03 (input via OI), 04 (external communication), 05 (option 1), 06 (option 2), 07 (pulse-string frequency input)	02	02	02	02	×	○
	A142	Operation-target frequency selection 2	00 (digital operator), 01 (keypad potentiometer), 02 (input via O), 03 (input via OI), 04 (external communication), 05 (option 1), 06 (option 2), 07 (pulse-string frequency input)	03	03	03	03	×	○
	A143	Operator selection	00 (addition: A141 + A142), 01 (subtraction: A141 - A142), 02 (multiplication: A141 x A142)	00	00	00	00	×	○
	A145	Frequency to be added	0.00 to 99.99, 100.0 to 400.0 (Hz)	0.00	0.00	0.00	0.00	×	○
Acceleration and deceleration	A146	Sign of the frequency to be added	00 (frequency command + A145), 01 (frequency command - A145)	00	00	00	00	×	○
	A150	EL-S-curve acceleration ratio 1	0. to 50. (%)	25.	25.	25.	25.	×	×
	A151	EL-S-curve acceleration ratio 2	0. to 50. (%)	25.	25.	25.	25.	×	×
	A152	EL-S-curve deceleration ratio 1	0. to 50. (%)	25.	25.	25.	25.	×	×
	A153	EL-S-curve deceleration ratio 2	0. to 50. (%)	25.	25.	25.	25.	×	×

● B GROUP: FINE TUNING FUNCTIONS

Code	Function Name	Monitored data or setting	Default Setting				Setting during operation (allowed or not)	Change during operation (allowed or not)	
			SJ700			L700			
			-FE(CE)	-FU(UL)	-F(JP)				
Restart after instantaneous power failure or tripping	b001	Selection of restart mode	00 (tripping), 01 (starting with 0 Hz), 02 (starting with matching frequency), 03 (tripping after deceleration and stopping with matching frequency), 04 (restarting with active matching frequency)	00	00	00	00	×	○
	b002	Allowable under-voltage power failure time	0.3 to 25.0 (s)	1.0	1.0	1.0	1.0	×	○
	b003	Retry wait time before motor restart	0.3 to 100.0 (s)	1.0	1.0	1.0	1.0	×	○
	b004	Instantaneous power failure/under-voltage trip alarm enable	00 (disabling), 01 (enabling), 02 (disabling during stopping and decelerating to stop)	00	00	00	00	×	○
	b005	Number of restarts on power failure/under-voltage trip events	00 (16 times), 01 (unlimited)	00	00	00	00	×	○
	b006	Phase loss detection enable	00 (disabling), 01 (enabling)	00	00	00	00	×	○
	b007	Restart frequency threshold	0.00 to 99.99, 100.0 to 400.0 (Hz)	0.00	0.00	0.00	0.00	×	○
	b008	Selection of retry after tripping	00 (tripping), 01 (starting with 0 Hz), 02 (starting with matching frequency), 03 (tripping after deceleration and stopping with matching frequency), 04 (restarting with active matching frequency)	00	00	00	00	×	○
	b009	Selection of retry after undervoltage	00 (16 times), 01 (unlimited)	00	00	00	00	×	○
	b010	Selection of retry count after overvoltage or overcurrent	1 to 3 (times)	3	3	3	3	×	○
Electronic thermal function	b011	Retry wait time after tripping	0.3 to 100.0 (s)	1.0	1.0	1.0	1.0	×	○
	b012	Electronic thermal setting (calculated within the inverter from current output)	0.20 x "rated current" to 1.00 x "rated current" (A)	Rated current of inverter x 1.0				×	○
	b212	Electronic thermal setting (calculated within the inverter from current output), 2nd motor	0.20 x "rated current" to 1.00 x "rated current" (A)	Rated current of inverter x 1.0				×	○
	b312	Electronic thermal setting (calculated within the inverter from current output), 3rd motor	0.20 x "rated current" to 1.00 x "rated current" (A)	Rated current of inverter x 1.0				×	○
	b013	Electronic thermal characteristic	00 (reduced-torque characteristic), 01 (constant-torque characteristic), 02 (free setting)	01	01	00	01	×	○
	b213	Electronic thermal characteristic, 2nd motor	00 (reduced-torque characteristic), 01 (constant-torque characteristic), 02 (free setting)	01	01	00	01	×	○
	b313	Electronic thermal characteristic, 3rd motor	00 (reduced-torque characteristic), 01 (constant-torque characteristic), 02 (free setting)	01	01	00	01	×	○
	b015	Free-setting electronic thermal frequency (1)	0. to 400. (Hz)	0.	0.	0.	0.	×	○
	b016	Free-setting electronic thermal current (1)	0.00 to rated current (A)	0.0	0.0	0.0	0.0	×	○
	b017	Free-setting electronic thermal frequency (2)	0. to 400. (Hz)	0.	0.	0.	0.	×	○
Overload restriction and overcurrent restraint	b018	Free-setting electronic thermal current (2)	0.00 to rated current (A)	0.0	0.0	0.0	0.0	×	○
	b019	Free-setting electronic thermal frequency (3)	0. to 400. (Hz)	0.	0.	0.	0.	×	○
	b020	Free-setting electronic thermal current (3)	0.00 to rated current (A)	0.0	0.0	0.0	0.0	×	○
	b021	Overload restriction operation mode	00 (disabling), 01 (enabling during acceleration and deceleration), 02 (enabling during constant speed), 03 (enabling during acceleration and deceleration (increasing the speed during regeneration))	01	01	01	01	×	○
	b022	Overload restriction setting	SJ700: 0.20 x "rated current" to 2.00 x "rated current" (A) < 75kW and over: 0.20 x 1.50 > L700: 0.20 x "rated current" to 1.50 x "rated current" (A)	Rated current x 1.50			Rated current x 1.20	×	○
	b023	Deceleration rate at overload restriction	0.10 to 30.0 (s)	1.00	1.00	1.00	1.00	×	○
	b024	Overload restriction operation mode (2)	00 (disabling), 01 (enabling during acceleration and deceleration), 02 (enabling during constant speed), 03 (enabling during acceleration and deceleration (increasing the speed during regeneration))	01	01	01	01	×	○
	b025	Overload restriction setting (2)	SJ700: 0.20 x "rated current" to 2.00 x "rated current" (A) < 75kW and over: 0.20 x 1.50 > L700: 0.20 x "rated current" to 1.50 x "rated current" (A)	Rated current x 1.50			Rated current x 1.20	×	○
	b026	Deceleration rate at overload restriction (2)	0.10 to 30.0 (s)	1.00	1.00	1.00	1.00	×	○
	b027	Overcurrent suppression enable	00 (disabling), 01 (enabling)	01	01	01	01	×	○

Code	Function Name	Monitored data or setting	Default Setting				Setting during operation (allowed or not)	Change during operation (allowed or not)
			SJ700			L700		
			FE(CE)	-FU(UL)	-F(JP)			
Overload restriction and overcurrent restrict	b028	Active frequency matching, scan start frequency	SJ700: 0.20 x "rated current" to 2.00 x "rated current" (A) < 75kW and over:0.20 x 1.50 > L700: 0.20 x "rated current" to 1.50 x "rated current" (A)				Rated current of inverterx 1.0	
	b029	Active frequency matching, scan-time constant	0.10 to 30.00 (s)				0.50	0.50
	b030	Active frequency matching, restart frequency select	00 (frequency at the last shutoff), 01 (maximum frequency), 02 (set frequency)				00	00
software lock	b031	Software lock mode selection	00 (disabling change of data other than "b031" when SFT is on), 01 (disabling change of data other than "b031" and frequency settings when SFT is on), 02 (disabling change of data other than "b031"), 03 (disabling change of data other than "b031" and frequency settings), 10 (enabling data changes during operation)				01	01
	b034	RUN/ power-on warning time	0. to 9999. (0 to 99990), 1000 to 6553 (10000 to 655300) (hr)				0.	0.
	b035	Rotational direction restriction	00 (enabling both forward and reverse rotations), 01 (enabling only forward rotation), 02 (enabling only reverse rotation)				00	00
	b036	Reduced voltage start selection	0 (minimum reduced voltage start time) to 255 (maximum reduced voltage start time)				06	06
	b037	Function code display restriction	00 (full display), 01 (function-specific display), 02 (user setting), 03 (data comparison display), 04 (basic display)				04	04
	b038	Initial-screen selection	00 (screen displayed when the STR key was pressed last), 01 (d001), 02 (d002), 03 (d003), 04 (d007), 05 (F001)				01	01
	b039	Automatic user-parameter setting function enable	00 (disabling), 01 (enabling)				00	00
Others	b040	Torque limit selection	00 (quadrant-specific setting), 01 (switching by terminal), 02 (analog input), 03 (option 1), 04 (option 2)				00	00
	b041	Torque limit(1) (Forward-driving in 4-quadrant mode)	SJ700: 0. to 200. (%), no (disabling torque limitation) < 75kW and over:0. to 180.> L700: 0. to 150.(%), no (disabling torque limitation)				150.	150.
	b042	Torque limit(2) (Reverse-regenerating in 4-quadrant mode)	SJ700: 0. to 200. (%), no (disabling torque limitation) < 75kW and over:0. to 180.> L700: 0. to 150.(%), no (disabling torque limitation)				150.	150.
	b043	Torque limit(3) (Reverse-driving in 4-quadrant mode)	SJ700: 0. to 200. (%), no (disabling torque limitation) < 75kW and over:0. to 180.> L700: 0. to 150.(%), no (disabling torque limitation)				150.	150.
	b044	Torque limit(4) (Forward-regenerating in 4-quadrant mode)	SJ700: 0. to 200. (%), no (disabling torque limitation) < 75kW and over:0. to 180.> L700: 0. to 150.(%), no (disabling torque limitation)				150.	150.
Torque limitation	b045	Torque limit LADSTOP enable	00 (disabling), 01 (enabling)				00	00
	b046	Reverse RUN protection enable	00 (disabling), 01 (enabling)				00	00
	b050	Controlled deceleration and stop on power loss	00 (disabling), 01 (enabling)				00	00
	b051	DC bus voltage trigger level during power loss	0.0 to 999.9, 1000. (V)				220.0/440.0	220.0/440.0
	b052	Over-voltage threshold during power loss	0.0 to 999.9, 1000. (V)				360.0/720.0	360.0/720.0
	b053	Deceleration time setting during power loss	0.01 to 99.99, 100.0 to 999.9, 1000. to 3600. (s)				1.00	1.00
	b054	Initial output frequency decrease during power loss	0.00 to 10.00 (Hz)				0.00	0.00
	b055	Proportional gain setting for nonstop operation at power loss	0.00 to 2.55				0.20	0.20
	b056	Integral time setting for nonstop operation at power loss	0.0 to 9.999 /10.0 to 65.55				0.100	0.100
	b060	Maximum-limit level of window comparators O	0. to 100. (lower limit : b061 + b062*2) (%)				100	100
	Window comparator	b061	Minimum-limit level of window comparators O	0. to 100. (lower limit : b060 - b062*2) (%)				0
b062		Hysteresis width of window comparators O	0. to 10. (lower limit : b061 - b062 / 2) (%)				0	0
b063		Maximum-limit level of window comparators OI	0. to 100. (lower limit : b064 + b066*2) (%)				100	100
b064		Minimum-limit level of window comparators OI	0. to 100. (lower limit : b063 - b066*2) (%)				0	0
b065		Hysteresis width of window comparators OI	0. to 10. (lower limit : b063 - b064 / 2) (%)				0	0
b066		Maximum-limit level of window comparators OI	-100. to 100. (lower limit : b067 + b068*2) (%)				100	100
b067		Minimum-limit level of window comparators OI/OI/O2	-100. to 100. (lower limit : b066 - b068*2) (%)				-100	-100
b068		Hysteresis width of window comparators OI/OI/O2	0. to 10. (lower limit : b066 - b067 / 2) (%)				0	0
b070		Operation level at O disconnection	0 to 100 (%) or "no" (ignore)				255(no)	255(no)
b071		Operation level at OI disconnection	0 to 100 (%) or "no" (ignore)				255(no)	255(no)
b072		Operation level at O2 disconnection	0 to 100 (%) or "no" (ignore)				127(no)	127(no)
Others	b078	Cumulative input power data clearance	Clearance by setting "01" and pressing the STR key				00	00
	b079	Cumulative input power display gain setting	1. to 1000.				1.	1.
	b082	Start frequency adjustment	0.10 to 9.99 (Hz)				0.50	0.50
	b083	Carrier frequency setting	SJ700: 0.5 to 15.0(kHz) <75 to 132kW>0.5 to 10.0/185kW and over:0.5 to 3.0> L700: 0.5 to 12.0 (kHz) <90kW and over:0.5 to 8.0.>				5.0	5.0
	b084	Initialization mode (parameters or trip history)	00 (clearing the trip history), 01 (initializing the data), 02 (clearing the trip history and initializing the data)				00	00
	b085	Country code for initialization	00 (Japan), 01 (EU), 02 (U.S.A.)				01	02
	b086	Frequency scaling conversion factor	0.1 to 99.0				1.0	1.0
	b087	STOP key enable	00 (enabling), 01 (disabling), 02 (disabling only the function to stop)				00	00
	b088	Restart mode after FRS	00 (starting with 0 Hz), 01 (starting with matching frequency), 02 (starting with active matching frequency)				00	00
	b089	Automatic carrier frequency reduction	00: invalid, 01: valid				00	00
	b090	Dynamic braking usage ratio	0.0 to 100.0 (%)				0.0	0.0
Free setting of V/f characteristic	b091	Stop mode selection	00 (deceleration until stop), 01 (free-run stop)				00	00
	b092	Cooling fan control	00 (always operating the fan), 01 (operating the fan only during inverter operation [including 5 minutes after power-on and power-off])				00	00
	b095	Dynamic braking control	00 (disabling), 01 (enabling [disabling while the motor is topped]), 02 (enabling [enabling also while the motor is topped])				00	00
	b096	Dynamic braking activation level	330 to 380, 660 to 760(V)				360/720	360/720
	b098	Thermistor for thermal protection control	00 (disabling the thermistor), 01 (enabling the thermistor with PTC), 02 (enabling the thermistor with NTC)				00	00
	b099	Thermal protection level setting	0. to 9999. (Ω)				3000.	3000.
	b100	Free-setting V/f frequency (1)	0. to "free-setting V/f frequency (2)" (Hz)				0.	0.
	b101	Free-setting V/f voltage (1)	0.0 to 800.0 (V)				0.0	0.0
	b102	Free-setting V/f frequency (2)	0. to "free-setting V/f frequency (3)" (Hz)				0.	0.
	b103	Free-setting V/f voltage (2)	0.0 to 800.0 (V)				0.0	0.0
	b104	Free-setting V/f frequency (3)	0. to "free-setting V/f frequency (4)" (Hz)				0.	0.
b105	Free-setting V/f voltage (3)	0.0 to 800.0 (V)				0.0	0.0	
b106	Free-setting V/f frequency (4)	0. to "free-setting V/f frequency (5)" (Hz)				0.	0.	
b107	Free-setting V/f voltage (4)	0.0 to 800.0 (V)				0.0	0.0	
b108	Free-setting V/f frequency (5)	0. to "free-setting V/f frequency (6)" (Hz)				0.	0.	
b109	Free-setting V/f voltage (5)	0.0 to 800.0 (V)				0.0	0.0	
b110	Free-setting V/f frequency (6)	0. to "free-setting V/f frequency (7)" (Hz)				0.	0.	
b111	Free-setting V/f voltage (6)	0.0 to 800.0 (V)				0.0	0.0	

*1 "Over current protection", "Overload restriction", "Over current limiting" and "Electronic thermal protection" might operate from the set value when "Carrier frequency setting" is used with less than 2kHz by a low value. Please set to 2kHz or more and use the setting of "Carrier frequency setting" for such a situation.

Code	Function Name	Monitored data or setting	Default Setting				Setting during operation (allowed or not)	Change during operation (allowed or not)					
			SJ700			L700							
			-FE(CE)	-FU(UL)	-F(JP)								
Others	b112	Free-setting V/f frequency (7)	0.0 to 400.0 (Hz)				0.	0.	0.	0.	×	×	
	b113	Free-setting V/f voltage (7)	0.0 to 800.0 (V)				0.0	0.0	0.0	0.0	×	×	
	b120	Brake control enable	00 (disabling), 01 (enabling)				00	00	00	×	×	○	
	b121	Brake wait time for release	0.00 to 5.00 (s)				0.00	0.00	0.00	×	×	○	
	b122	Brake wait time for acceleration	0.00 to 5.00 (s)				0.00	0.00	0.00	×	×	○	
	b123	Brake wait time for stopping	0.00 to 5.00 (s)				0.00	0.00	0.00	×	×	○	
	b124	Brake wait time for confirmation	0.00 to 5.00 (s)				0.00	0.00	0.00	×	×	○	
	b125	Brake release frequency setting	0.00 to 99.99, 100.0 to 400.0 (Hz)				0.00	0.00	0.00	×	×	○	
	b126	Brake release current setting	0.0 to 2.00 x "rated current"				Rated current x 1.00				×	×	○
	b127	Braking frequency	0.00 to 99.99, 100.0 to 400.0 (Hz)				0.00	0.00	0.00	×	×	○	
	b130	Overvoltage suppression enable	00 (disabling the restraint), 01 (decelerating and stagnating), 02 (enabling acceleration)				00	00	00	00	×	○	
	b131	Overvoltage suppression level	330 to 390 (V) (200 V class model), 660 to 780 (V) (400 V class model)				380/760	380/760	380/760	380/760	×	○	
	b132	Acceleration and deceleration rate at overvoltage suppression	0.10 to 30.00 (s)				1.00	1.00	1.00	1.00	×	○	
	b133	Overvoltage suppression proportional gain	0.00 to 2.55				0.50	0.50	0.50	0.50	○	○	
b134	Overvoltage suppression Integral time	0.000 to 9.999 / 10.00 to 63.53 (s)				0.060	0.060	0.060	0.060	○	○		

● C GROUP: INTELLIGENT TERMINAL FUNCTIONS

Code	Function Name	Monitored data or setting	Default Setting				Setting during operation (allowed or not)	Change during operation (allowed or not)				
			SJ700			L700						
			-FE(CE)	-FU(UL)	-F(JP)							
Intelligent input terminals	C001	Terminal [1] function (*1)	01 (RV: Reverse RUN), 02 (CF1: Multispeed 1 setting), 03 (CF2: Multispeed 2 setting), 04 (CF3: Multispeed 3 setting), 05 (CF4: Multispeed 4 setting), 06 (JG: Jogging), 07 (DB: external DC braking), 08 (SET: Set 2nd motor data), 09 (2CH: 2-stage acceleration/deceleration), 11 (FRS: free-run stop), 12 (EXT: external trip), 13 (USP: unattended start protection), 14 (CS: commercial power source enable), 15 (SFT: software lock), 16 (AT: analog input voltage/current select), 17 (SET3: 3rd motor control), 18 (RS: reset), 20 (STA: starting by 3-wire input), 21 (STP: stopping by 3-wire input), 22 (F/R: forward/reverse switching by 3-wire input), 23 (PID: PID disable), 24 (PIDC: PID reset), 26 (CAS: control gain setting), 27 (UP: remote control UP function), 28 (DWN: remote control DOWN function), 29 (DWN: remote control data clearing), 31 (OPE: forcible operation), 32 (SF1: multispeed bit 1), 33 (SF2: multispeed bit 2), 34 (SF3: multispeed bit 3), 35 (SF4: multispeed bit 4), 36 (SF5: multispeed bit 5), 37 (SF6: multispeed bit 6), 38 (SF7: multispeed bit 7), 39 (OLR: overload restriction selection), 40 (TL: torque limit enable), 41 (TRQ1: torque limit selection bit 1), 42 (TRQ2: torque limit selection bit 2), 43 (PPI: P/P mode selection), 44 (BOK: braking confirmation)(*2), 45 (ORT: orientation)(*2), 46 (LAC: LAD cancellation), 47 (PCLR: clearance of position deviation)(*2), 48 (STAT: pulse train position command input enable)(*2), 50 (ADD: trigger for frequency addition [A145]), 51 (F-TM: forcible-terminal operation), 52 (ATR: permission of torque command input)(*2), 53 (KHC: cumulative power clearance), 54 (SON: servo-on)(*2), 55 (FOC: pre-excitation)(*2), 56 (MI1: general-purpose input 1), 57 (MI2: general-purpose input 2), 58 (MI3: general-purpose input 3), 59 (MI4: general-purpose input 4), 60 (MI5: general-purpose input 5), 61 (MI6: general-purpose input 6), 62 (MI7: general-purpose input 7), 63 (MI8: general-purpose input 8), 64 (EMR: Emergency stop)(*1), 65 (AHD: analog command holding), 66 (CP1: multistage position settings selection 1)(*2), 67 (CP2: multistage position settings selection 2)(*2), 68 (CP3: multistage position settings selection 3)(*2), 69 (ORL: Zero-return limit function)(*2), 70 (ORG: Zero-return trigger function)(*2), 71 (FOT: forward drive stop)(*2), 72 (ROT: reverse drive stop)(*2), 73 (SPD: speed / position switching)(*2), 74 (PCNT: pulse counter), 75 (PCC: pulse counter clear), no (NO: no assignment)				18(RS)	18(RS)	18(RS)	18(RS)	×	○
	C002	Terminal [2] function					16(AT)	16(AT)	16(AT)	16(AT)	×	○
	C003	Terminal [3] function (*1)					06(JG)	06(JG)	06(JG)	03(CF2)	×	○
	C004	Terminal [4] function					11(FRS)	11(FRS)	11(FRS)	02(CF1)	×	○
	C005	Terminal [5] function					09(2CH)	09(2CH)	09(2CH)	01(RV)	×	○
	C006	Terminal [6] function					03(CF2)	13(USP)	03(CF2)	06(JG)	×	○
	C007	Terminal [7] function					02(CF1)	02(CF1)	02(CF1)	11(FRS)	×	○
	C008	Terminal [8] function					01(RV)	01(RV)	01(RV)	13(USP)	×	○
Intelligent input terminals	C011	Terminal (1) active state	00(NO) / 01(NC)				00	00	00	00	×	○
	C012	Terminal (2) active state	00(NO) / 01(NC)				00	00	00	00	×	○
	C013	Terminal (3) active state	00(NO) / 01(NC)				00	00	00	00	×	○
	C014	Terminal (4) active state	00(NO) / 01(NC)				00	00	00	00	×	○
	C015	Terminal (5) active state	00(NO) / 01(NC)				00	00	00	00	×	○
	C016	Terminal (6) active state	00(NO) / 01(NC)				00	01	00	00	×	○
	C017	Terminal (7) active state	00(NO) / 01(NC)				00	00	00	00	×	○
	C018	Terminal (8) active state	00(NO) / 01(NC)				00	00	00	00	×	○
	C019	Terminal FW active state	00(NO) / 01(NC)				00	00	00	00	×	○
Intelligent output terminals	C021	Terminal (11) function	00 (RUN: running), 01 (FA1: constant-speed reached), 02 (FA2: set frequency overreached), 03 (OL: overload notice advance signal (1)), 04 (OD: output deviation for PID control), 05 (AL: alarm signal), 06 (FA3: set frequency reached), 07 (OTQ: over-torque), 08 (IP: instantaneous power failure), 09 (UV: undervoltage), 10 (TRQ: torque limited), 11 (RNT: operation time over), 12 (ONT: plug-in time over), 13 (THM: thermal alarm signal), 19 (BRK: brake release)(*2), 20 (BER: braking error)(*2), 21 (ZS: 0 Hz detection signal), 22 (DSE: speed deviation maximum)(*2), 23 (POK: positioning completed)(*2), 24 (FA4: set frequency overreached 2), 25 (FA5: set frequency reached 2), 26 (OL2: overload notice advance signal (2)), 27 (Odc: Analog O disconnection detection), 28 (OIDc: Analog OI disconnection detection), 29 (O2dc: Analog O2 disconnection detection), 31 (FBV: PID feedback comparison), 32 (NDC: communication line disconnection), 33 (LOG1: logical operation result 1), 34 (LOG2: logical operation result 2), 35 (LOG3: logical operation result 3), 36 (LOG4: logical operation result 4), 37 (LOG5: logical operation result 5), 38 (LOG6: logical operation result 6), 39 (WAC: capacitor life warning), 40 (WAF: cooling-fan speed drop), 41 (FR: starting contact signal), 42 (OHF: heat sink overheat warning), 43 (LOC: low-current indication signal), 44 (MO1: general-purpose output 1), 45 (MO2: general-purpose output 2), 46 (MO3: general-purpose output 3), 47 (MO4: general-purpose output 4), 48 (MO5: general-purpose output 5), 49 (MO6: general-purpose output 6), 50 (IRDY: inverter ready), 51 (FWR: forward rotation), 52 (RVR: reverse rotation), 53 (MJA: major failure), 54 (WCO: window comparator O), 55 (WCOI: window comparator OI), 56 (WCO2: window comparator O2) (When alarm code output is selected for "C062", functions "AC0" to "AC2" or "AC0" to "AC3" [ACn: alarm code output] are forcibly assigned to intelligent output terminals 11 to 13 or 11 to 14, respectively.)				01(FA1)	01(FA1)	01(FA1)	01(FA1)	×	○
	C022	Terminal (12) function					00(RUN)	00(RUN)	00(RUN)	00(RUN)	×	○
	C023	Terminal (13) function					03(OL)	03(OL)	03(OL)	03(OL)	×	○
	C024	Terminal (14) function					07(OTO)	07(OTO)	07(OTO)	07(OTO)	×	○
	C025	Terminal (15) function					40(WAF)	40(WAF)	40(WAF)	40(WAF)	×	○
	C026	Alarm relay terminal function					05(AL)	05(AL)	05(AL)	05(AL)	×	○
Analog monitoring	C027	FM signal selection	00 (output frequency), 01 (output current), 02 (output torque), 03 (digital output frequency), 04 (output voltage), 05 (input power), 06 (electronic thermal overload), 07 (LAD frequency), 08 (digital current monitoring), 09 (motor temperature), 10 (heat sink temperature), 12 (general-purpose output YA0)				00	00	00	00	×	○
	C028	AM signal selection	00 (output frequency), 01 (output current), 02 (output torque), 04 (output voltage), 05 (input power), 06 (electronic thermal overload), 07 (LAD frequency), 09 (motor temperature), 10 (heat sink temperature), 11 (output torque [signed value]), 13 (general-purpose output YA1)				00	00	00	00	×	○
	C029	AMI signal selection	00 (output frequency), 01 (output current), 02 (output torque), 04 (output voltage), 05 (input power), 06 (electronic thermal overload), 07 (LAD frequency), 09 (motor temperature), 10 (heat sink temperature), 14 (general-purpose output YA2)				00	00	00	00	×	○

*1 When the emergency stop function is enabled (SW1 = ON), "18" (RS) and "64" (EMR) are forcibly written to parameters "C001" and "C003", respectively. (You cannot arbitrarily write "64" to "C001".) If the SW1 signal is turned off and then turned on, "no" (no assignment) is set in parameter "C003".

*2 L700 series: The function is not provided.

OC GROUP: INTELLIGENT TERMINAL FUNCTIONS

[O= Allowed X= Not permitted]

Code	Function Name	Monitored data or setting	Default Setting				Setting during operation (allowed or not)	Change during operation (allowed or not)				
			SJ700			L700						
			-FE(CE)	-FU(UL)	-FJP)							
Always monitoring	C030	Digital current monitor reference value	SJ700:0.20 x "rated current" to 2.00 x "rated current" (A) / L700:0.20 x "rated current" to 1.50 x "rated current" (A) (Current with digital current monitor output at 1,440 Hz)				Rated current of inverterx 1..0		O	O		
	C031	Terminal (11) active state	00(NO) / 01(NC)				00	00	00	00	X	O
	C032	Terminal (12) active state	00(NO) / 01(NC)				00	00	00	00	X	O
	C033	Terminal (13) active state	00(NO) / 01(NC)				00	00	00	00	X	O
	C034	Terminal (14) active state	00(NO) / 01(NC)				00	00	00	00	X	O
	C035	Terminal (15) active state	00(NO) / 01(NC)				00	00	00	00	X	O
Intelligent output terminals	C036	Alarm relay terminal active state	00(NO) / 01(NC)				01	01	01	01	X	O
	C038	Low-current indication signal output mode selection	00 (output during acceleration/deceleration and constant-speed operation), 01 (output only during constant-speed operation)				01	01	01	01	X	O
	C039	Low-current indication signal detection level	SJ700:0.0 to 2.00 x "rated current" (A) / L700:0.0 to 1.50 x "rated current" (A)				Rated current of inverterx 1..0				X	O
	C040	Overload signal output mode	00 (output during acceleration/deceleration and constant-speed operation), 01 (output only during constant-speed operation)				01	01	01	01	X	O
	C041	Overload level setting	SJ700:0.0 to 2.00 x "rated current" (A) / L700:0.0 to 1.50 x "rated current" (A)				Rated current of inverterx 1..0				X	O
	C042	Frequency arrival setting for accel.	0.00 to 99.99, 100.0 to 400.0 (Hz)				0.00	0.00	0.00	0.00	X	O
	C043	Frequency arrival setting for decel.	0.00 to 99.99, 100.0 to 400.0 (Hz)				0.00	0.00	0.00	0.00	X	O
	C044	PID deviation level setting	0.0 to 100.0 (%)				3.0	3.0	3.0	3.0	X	O
	C045	Frequency arrival setting for acceleration (2)	0.00 to 99.99, 100.0 to 400.0 (Hz)				0.00	0.00	0.00	0.00	X	O
	C046	Frequency arrival setting for deceleration (2)	0.00 to 99.99, 100.0 to 400.0 (Hz)				0.00	0.00	0.00	0.00	X	O
	C052	Maximum PID feedback data	0.0 to 100.0 (%)				100.0	100.0	100.0	100.0	X	O
	C053	Minimum PID feedback data	0.0 to 100.0 (%)				0.0	0.0	0.0	0.0	X	O
	C055	Over-torque(Forward-driving) level setting	SJ700: 0. to 200. (%) < 75kW and over:0. to 180.> L700: 0. to 150. (%)				100.	100.	100.	100.	X	O
	C056	Over-torque(Reverse-regenerating) level setting	SJ700: 0. to 200. (%) < 75kW and over:0. to 180.> L700: 0. to 150. (%)				100.	100.	100.	100.	X	O
	C057	Over-torque(Reverse-driving) level setting	SJ700: 0. to 200. (%) < 75kW and over:0. to 180.> L700: 0. to 150. (%)				100.	100.	100.	100.	X	O
C058	Over-torque(Forward-regenerating) level setting	SJ700: 0. to 200. (%) < 75kW and over:0. to 180.> L700: 0. to 150. (%)				100.	100.	100.	100.	X	O	
C061	Electronic thermal warning level setting	0. to 100. (%)				80.	80.	80.	80.	X	O	
C062	Alarm code input	00(Disabled) / 01(3-bit) / 02(4-bit)				00	00	00	00	X	O	
C063	Zero speed detection level	0.00 to 99.99, 100.0 (Hz)				0.00	0.00	0.00	0.00	X	O	
C064	Heat sink overheat warning level	0. to 200.0 (°C)				120.	120.	120.	120.	X	O	
C071	Communication speed selection	02 (loopback test), 03 (2,400 bps), 04 (4,800 bps), 05 (9,600 bps), 06 (19,200 bps)				04	04	04	04	X	O	
C072	Node allocation	1. to 32.				1.	1.	1.	1.	X	O	
C073	Communication data length selection	7 (7 bits), 8 (8 bits)				7	7	7	7	X	O	
C074	Communication parity selection	00 (no parity), 01 (even parity), 02 (odd parity)				00	00	00	00	X	O	
C075	Communication stop bit selection	1 (1 bit), 2 (2 bits)				1	1	1	1	X	O	
C076	Selection of the operation after communication error	00 (tripping), 01 (tripping after decelerating and stopping the motor), 02 (ignoring errors), 03 (stopping the motor after free-running), 04 (decelerating and stopping the motor)				02	02	02	02	X	O	
C077	Communication timeout limit before tripping	0.00 to 99.99 (s)				0.00	0.00	0.00	0.00	X	O	
C078	Communication wait time	0. to 1000. (ms)				0.	0.	0.	0.	X	O	
C079	Communication mode selection	00(ASCII), 01(Modbus-RTU)				00	00	00	00	X	O	
C081	O input span calibration	0. to 9999., 1000 to 6553(10000 to 65530)				Factory set				X	O	
C082	O1 input span calibration	0. to 9999., 1000 to 6553(10000~65530)								X	O	
C083	O2 input span calibration	0. to 9999., 1000 to 6553(10000~65530)								X	O	
C085	Thermistor input tuning	0.0 to 999.9, 1000.								X	O	
C091	Debug mode enable	(Do not change this parameter, which is intended for factory adjustment.)				00	00	00	00	X	X	
C101	UP/DOWN memory mode selection	00 (not storing the frequency data), 01 (storing the frequency data)				00	00	00	00	X	O	
C102	Reset mode selection	00 (resetting the trip when RS is on), 01 (resetting the trip when RS is off), 02 (enabling resetting only upon tripping [resetting when RS is on])				00	00	00	00	O	O	
C103	Restart mode after reset	00 (starting with 0 Hz), 01 (starting with matching frequency), 02 (restarting with active matching frequency)				00	00	00	00	X	O	
C105	FM gain adjustment	50. to 200. (%)				100.	100.	100.	100.	O	O	
C106	AM gain adjustment	50. to 200. (%)				100.	100.	100.	100.	O	O	
C107	AMI gain adjustment	50. to 200. (%)				100.	100.	100.	100.	O	O	
C109	AM bias adjustment	0. to 100. (%)				0.	0.	0.	0.	O	O	
C110	AMI bias adjustment	0. to 100. (%)				20.	20.	20.	20.	O	O	
C111	Overload setting (2)	SJ700:0.0 to 2.00 x "rated current" (A) <75kW and over:0.0 to 1.80 x "rated current"> L700:0.0 to 1.50 x "rated current" (A)				Rated current of inverterx 1..0				X	O	
C121	O input zero calibration	0. to 9999., 1000 to 6553 (10000 to 65530)				Factory set				O	O	
C122	O1 input zero calibration	0. to 9999., 1000 to 6553 (10000 to 65530)								O	O	
C123	O2 input zero calibration	0. to 9999., 1000 to 6553 (10000 to 65530)								O	O	
C130	Output 11 on-delay time	0.0 to 100.0 (s)				0.0	0.0	0.0	0.0	O	O	
C131	Output 11 off-delay time	0.0 to 100.0 (s)				0.0	0.0	0.0	0.0	X	O	
C132	Output 12 on-delay time	0.0 to 100.0 (s)				0.0	0.0	0.0	0.0	X	O	
C133	Output 12 off-delay time	0.0 to 100.0 (s)				0.0	0.0	0.0	0.0	X	O	
C134	Output 13 on-delay time	0.0 to 100.0 (s)				0.0	0.0	0.0	0.0	X	O	
C135	Output 13 off-delay time	0.0 to 100.0 (s)				0.0	0.0	0.0	0.0	X	O	
C136	Output 14 on-delay time	0.0 to 100.0 (s)				0.0	0.0	0.0	0.0	X	O	
C137	Output 14 off-delay time	0.0 to 100.0 (s)				0.0	0.0	0.0	0.0	X	O	
C138	Output 15 on-delay time	0.0 to 100.0 (s)				0.0	0.0	0.0	0.0	X	O	
C139	Output 15 off-delay time	0.0 to 100.0 (s)				0.0	0.0	0.0	0.0	X	O	
C140	Output RY on-delay time	0.0 to 100.0 (s)				0.0	0.0	0.0	0.0	X	O	
C141	Output RY off-delay time	0.0 to 100.0 (s)				0.0	0.0	0.0	0.0	X	O	
C142	Logical output signal 1 selection 1	Same as the settings of C021 to C026 (except those of LOG1 to LOG6)				00	00	00	00	X	O	
C143	Logical output signal 1 selection 2	Same as the settings of C021 to C026 (except those of LOG1 to LOG6)				00	00	00	00	X	O	
C144	Logical output signal 1 operator selection	00 (AND), 01 (OR), 02 (XOR)				00	00	00	00	X	O	
C145	Logical output signal 2 selection 1	Same as the settings of C021 to C026 (except those of LOG1 to LOG6)				00	00	00	00	X	O	
C146	Logical output signal 2 selection 2	Same as the settings of C021 to C026 (except those of LOG1 to LOG6)				00	00	00	00	X	O	
C147	Logical output signal 2 operator selection	00 (AND), 01 (OR), 02 (XOR)				00	00	00	00	X	O	
C148	Logical output signal 3 selection 1	Same as the settings of C021 to C026 (except those of LOG1 to LOG6)				00	00	00	00	X	O	

[O= Allowed X= Not permitted]

Code	Function Name	Monitored data or setting	Default Setting				Setting during operation (allowed or not)	Change during operation (allowed or not)				
			SJ700			L700						
			-FE(CE)	-FU(UL)	-F(JP)							
Output terminal operation function	C149	Logical output signal 3 selection 2	Same as the settings of C021 to C026 (except those of LOG1 to LOG6)				00	00	00	00	X	O
	C150	Logical output signal 3 operator selection	00 (AND), 01 (OR), 02 (XOR)				00	00	00	00	X	O
	C151	Logical output signal 4 selection 1	Same as the settings of C021 to C026 (except those of LOG1 to LOG6)				00	00	00	00	X	O
	C152	Logical output signal 4 selection 2	Same as the settings of C021 to C026 (except those of LOG1 to LOG6)				00	00	00	00	X	O
	C153	Logical output signal 4 operator selection	00 (AND), 01 (OR), 02 (XOR)				00	00	00	00	X	O
	C154	Logical output signal 5 selection 1	Same as the settings of C021 to C026 (except those of LOG1 to LOG6)				00	00	00	00	X	O
	C155	Logical output signal 5 selection 2	Same as the settings of C021 to C026 (except those of LOG1 to LOG6)				00	00	00	00	X	O
	C156	Logical output signal 5 operator selection	00 (AND), 01 (OR), 02 (XOR)				00	00	00	00	X	O
	C157	Logical output signal 6 selection 1	Same as the settings of C021 to C026 (except those of LOG1 to LOG6)				00	00	00	00	X	O
	C158	Logical output signal 6 selection 2	Same as the settings of C021 to C026 (except those of LOG1 to LOG6)				00	00	00	00	X	O
Input terminal response	C159	Logical output signal 6 operator selection	00 (AND), 01 (OR), 02 (XOR)				00	00	00	00	X	O
	C160	Input terminal response time setting 1	0. to 200. (×2ms)				1	1	1	1	X	O
	C161	Input terminal response time setting 2	0. to 200. (×2ms)				1	1	1	1	X	O
	C162	Input terminal response time setting 3	0. to 200. (×2ms)				1	1	1	1	X	O
	C163	Input terminal response time setting 4	0. to 200. (×2ms)				1	1	1	1	X	O
	C164	Input terminal response time setting 5	0. to 200. (×2ms)				1	1	1	1	X	O
	C165	Input terminal response time setting 6	0. to 200. (×2ms)				1	1	1	1	X	O
	C166	Input terminal response time setting 7	0. to 200. (×2ms)				1	1	1	1	X	O
	C167	Input terminal response time setting 8	0. to 200. (×2ms)				1	1	1	1	X	O
	C168	Input terminal response time setting FW	0. to 200. (×2ms)				1	1	1	1	X	O
C169	Multistage speed/position determination time	0. to 200. (×10ms)				0	0	0	0	X	O	

H GROUP: MOTOR CONSTANTS FUNCTIONS

[O= Allowed X= Not permitted]

Code	Function Name	Monitored data or setting	Default Setting				Setting during operation (allowed or not)	Change during operation (allowed or not)									
			SJ700			L700											
			-FE(CE)	-FU(UL)	-F(JP)												
Control constants	H001	Auto-tuning Setting	00 (disabling auto-tuning), 01 (auto-tuning without rotation), 02 (auto-tuning with rotation)				00	00	00	00	X	X					
	H002	Motor data selection, 1st motor	00 (Hitachi standard data), 01 (auto-tuned data), 02 (auto-tuned data [with online auto-tuning function])				00	00	00	00	X	X					
	H202	Motor data selection, 2nd motor	00 (Hitachi standard data), 01 (auto-tuned data), 02 (auto-tuned data [with online auto-tuning function])				00	00	00	00	X	X					
	H003	Motor capacity, 1st motor	SJ700:0.20 to 400.0 (kW)/L700:0.20 to 160(kW)				Factory set				X	X					
	H203	Motor capacity, 2nd motor	SJ700:0.20 to 400.0 (kW)/L700:0.20 to 160(kW)				Factory set				X	X					
	H004	Motor poles setting, 1st motor	2, 4, 6, 8, 10 (poles)				4	4	4	4	X	X					
	H204	Motor poles setting, 2nd motor	2, 4, 6, 8, 10 (poles)				4	4	4	4	X	X					
	H005	Motor speed constant, 1st motor	0.001 to 9.999, 10.00 to 80.00 (10.000 to 80.000)				1,590	1,590	1,590	1,590	O	O					
	H205	Motor speed constant, 2nd motor	0.001 to 9.999, 10.00 to 80.00 (10.000 to 80.000)				1,590	1,590	1,590	1,590	O	O					
	H006	Motor stabilization constant, 1st motor	0. to 255.				100.	100.	100.	100.	O	O					
	H206	Motor stabilization constant, 2nd motor	0. to 255.				100.	100.	100.	100.	O	O					
	H306	Motor stabilization constant, 3rd motor	0. to 255.				100.	100.	100.	100.	O	O					
	H020	Motor constant R1, 1st motor	0.001 to 9.999, 10.00 to 65.53 (Ω)				Depending on motor capacity				X	X					
	H220	Motor constant R1, 2nd motor	0.001 to 9.999, 10.00 to 65.53 (Ω)								X	X					
	H021	Motor constant R2, 1st motor	0.001 to 9.999, 10.00 to 65.53 (Ω)								X	X					
	H221	Motor constant R2, 2nd motor	0.001 to 9.999, 10.00 to 65.53 (Ω)								X	X					
	H022	Motor constant L, 1st motor	0.01 to 99.99, 100.0 to 655.3 (mH)								X	X					
	H222	Motor constant L, 2nd motor	0.01 to 99.99, 100.0 to 655.3 (mH)								X	X					
	H023	Motor constant lo	0.01 to 99.99, 100.0 to 655.3 (A)								X	X					
	H223	Motor constant lo, 2nd motor	0.01 to 99.99, 100.0 to 655.3 (A)								X	X					
	H024	Motor constant J	0.001 to 9.999, 10.00 to 99.99, 100.0 to 999.9, 1000. to 9999.								X	X					
	H224	Motor constant J, 2nd motor	0.001 to 9.999, 10.00 to 99.99, 100.0 to 999.9, 1000. to 9999.								X	X					
	H030	Auto constant R1, 1st motor	0.001 to 9.999, 10.00 to 65.53 (Ω)								X	X					
	H230	Auto constant R1, 2nd motor	0.001 to 9.999, 10.00 to 65.53 (Ω)								X	X					
	H031	Auto constant R2, 1st motor	0.001 to 9.999, 10.00 to 65.53 (Ω)								X	X					
	H231	Auto constant R2, 2nd motor	0.001 to 9.999, 10.00 to 65.53 (Ω)								X	X					
	H032	Auto constant L, 1st motor	0.01 to 99.99, 100.0 to 655.3 (mH)								X	X					
	H232	Auto constant L, 2nd motor	0.01 to 99.99, 100.0 to 655.3 (mH)								X	X					
	H033	Auto constant lo, 1st motor	0.01 to 99.99, 100.0 to 655.3 (A)								X	X					
	H233	Auto constant lo, 2nd motor	0.01 to 99.99, 100.0 to 655.3 (A)								X	X					
	H034	Auto constant J, 1st motor	0.001 to 9.999, 10.00 to 99.99, 100.0 to 999.9, 1000. to 9999.								X	X					
	H234	Auto constant J, 2nd motor	0.001 to 9.999, 10.00 to 99.99, 100.0 to 999.9, 1000. to 9999.								X	X					
	Control constants	H050	PI proportional gain for 1st motor	0.0 to 999.9, 1000.							100.0	100.0	100.0	100.0	O	O	
		H250	PI proportional gain for 2nd motor	0.0 to 999.9, 1000.							100.0	100.0	100.0	100.0	O	O	
H051		PI integral gain for 1st motor	0.0 to 999.9, 1000.								100.0	100.0	100.0	100.0	O	O	
H251		PI integral gain for 2nd motor	0.0 to 999.9, 1000.								100.0	100.0	100.0	100.0	O	O	
H052		P proportional gain setting for 1st motor	0.01 to 10.00				1.00	1.00	1.00	1.00	O	O					
H252		P proportional gain setting for 2nd motor	0.01 to 10.00				1.00	1.00	1.00	1.00	O	O					
H060		Zero LV limit for 1st motor	0.0 to 100.0				100.	100.	100.	X	O	O					
H260		Zero LV limit for 2nd motor	0.0 to 100.0				100.	100.	100.	X	O	O					
H061		Zero LV starting boost current for 1st motor	0. to 50. (%)				50.	50.	50.	X	O	O					
H261		Zero LV starting boost current for 2nd motor	0. to 50. (%)				50.	50.	50.	X	O	O					
H070		Terminal selection PI proportional gain setting	0.0 to 999.9, 1000.				100.0	100.0	100.0	100.0	O	O					
H071		Terminal selection PI integral gain setting	0.0 to 999.9, 1000.				100.0	100.0	100.0	100.0	O	O					
H072		Terminal selection P proportional gain setting	0.00 to 10.00				1.00	1.00	1.00	1.00	O	O					
H073	Gain switching time	0. to 9999. (ms)				100.	100.	100.	100.	O	O						

● P GROUP: EXPANSION CARD FUNCTIONS

[○= Allowed ×= Not permitted]

Code	Function Name	Monitored data or setting	Default Setting				L700	Setting during operation (allowed or not)	Change during operation (allowed or not)
			SJ700						
			-FE(CE)	-FU(UL)	-F(JP)				
P001	Operation mode on expansion card 1 error	00 (tripping), 01 (continuing operation)	00	00	00	00	×	○	
P002	Operation mode on expansion card 2 error	00 (tripping), 01 (continuing operation)	00	00	00	00	×	○	
P011	Encoder pulse-per-revolution (PPR) setting	128. to 9999., 1000 to 6500 (10000 to 65000) (pulses)	1024	1024	1024	×	×	×	
P012	Control pulse setting	00 (ASR), 01 (APR), 02 (APR2), 03 (HAPR)	00	00	00	×	×	×	
P013	Pulse input mode setting	00 (mode 0), 01 (mode 1), 02 (mode 2)	00	00	00	×	×	×	
P014	Home search stop position setting	0. to 4095.	0.	0.	0.	×	×	○	
P015	Home search speed setting	"start frequency" to "maximum frequency" (up to 120.0) (Hz)	5.00	5.00	5.00	×	×	○	
P016	Home search direction setting	00 (forward), 01 (reverse)	00	00	00	×	×	×	
P017	Home search completion range setting	0. to 9999., 1000 (10000) (pulses)	5.	5.	5.	×	×	○	
P018	Home search completion delay time setting	0.00 to 9.99 (s)	0.00	0.00	0.00	×	×	○	
P019	Electronic gear set position selection	00 (feedback side), 01 (commanding side)	00	00	00	×	×	○	
P020	Electronic gear ratio numerator setting	0. to 9999.	1.	1.	1.	×	×	○	
P021	Electronic gear ratio denominator setting	0. to 9999.	1.	1.	1.	×	×	×	
P022	Feed-forward gain setting	0.00 to 99.99, 100.0 to 655.3	0.00	0.00	0.00	×	×	○	
P023	Position loop gain setting	0.00 to 99.99, 100.0	0.50	0.50	0.50	×	×	○	
P024	Position bias setting	-204 (-2048.) / -999. to 2048	0.	0.	0.	×	×	○	
P025	Temperature compensation thermistor enable	00 (no compensation), 01 (compensation)	00	00	00	00	×	○	
P026	Over-speed error detection level setting	0.0 to 150.0 (%)	135.0	135.0	135.0	×	×	○	
P027	Speed deviation error detection level setting	0.00 to 99.99, 100.0 to 120.0 (Hz)	7.50	7.50	7.50	×	×	×	
P028	Numerator of motor gear ratio	0. to 9999.	1.	1.	1.	×	×	○	
P029	Denominator of motor gear ratio	0. to 9999.	1.	1.	1.	×	×	○	
P031	Accel./decel. time input selection	00 (digital operator), 01 (option 1), 02 (option 2), 03 (easy sequence)	00	00	00	00	×	×	
P032	Positioning command input selection	00 (digital operator), 01 (option 1), 02 (option 2)	00	00	00	×	×	○	
P033	Torque command input selection	00 (O terminal), 01 (OI terminal), 02 (O2 terminal), 03 (digital operator)	00	00	00	×	×	×	
P034	Torque command setting	0. to 200. (%)	0.	0.	0.	×	○	○	
P035	Polarity selection at the torque command input via O2 terminal	00 (as indicated by the sign), 01 (depending on the operation direction)	00	00	00	×	×	×	
P036	Torque bias mode	00 (disabling the mode), 01 (digital operator), 02 (input via O2 terminal)	00	00	00	×	×	×	
P037	Torque bias value	-200. to +200. (%)	0.	0.	0.	×	○	○	
P038	Torque bias polarity selection	00 (as indicated by the sign), 01 (depending on the operation direction)	00	00	00	×	×	×	
P039	Speed limit for torque-controlled operation (forward rotation)	0.00 to "maximum frequency" (Hz)	0.00	0.00	0.00	×	○	○	
P040	Speed limit for torque-controlled operation (reverse rotation)	0.00 to "maximum frequency" (Hz)	0.00	0.00	0.00	×	○	○	
P044	DeviceNet comm watchdog timer	0.00 to 99.99 (s)	1.00	1.00	1.00	1.00	×	×	
P045	Inverter action on DeviceNet comm error	00 (tripping), 01 (tripping after decelerating and stopping the motor), 02 (ignoring errors), 03 (stopping the motor after free-running), 04 (decelerating and stopping the motor)	01	01	01	01	×	×	
P046	DeviceNet polled I/O : Output instance number	20, 21, 100	21	21	21	21	×	×	
P047	DeviceNet polled I/O : input instance number	70, 71, 101	71	71	71	71	×	×	
P048	Inverter action on DeviceNet idle mode	00 (tripping), 01 (tripping after decelerating and stopping the motor), 02 (ignoring errors), 03 (stopping the motor after free-running), 04 (decelerating and stopping the motor)	01	01	01	01	×	×	
P049	DeviceNet motor poles setting for RPM	0, 2, 4, 6, 8, 10, 12, 14, 16, 18, 20, 22, 24, 26, 28, 30, 32, 34, 36, 38 (poles)	00	00	00	00	×	×	
P055	Pulse-string frequency scale	1.0 to 50.0 (kHz)	25.0	25.0	25.0	25.0	×	○	
P056	Time constant of pulse-string frequency filter	0.01 to 2.00 (s)	0.10	0.10	0.10	0.10	×	○	
P057	Pulse-string frequency bias	-100. to +100. (%)	0.	0.	0.	0.	×	○	
P058	Pulse-string frequency limit	0. to 100. (%)	100.	100.	100.	100.	×	○	
P060	Multistage position setting 0-7	Position setting range reverse side – forward side	0	0	0	×	○	○	
P067		(upper 4 digits including "-")	0	0	0	×	○	○	
P068	Zero-return mode selection	00(Low) / 01 (Hi1) / 00 (Hi2)	00	00	00	×	○	○	
P069	Zero-return direction selection	00 (FW) / 01 (RV)	00	00	00	×	○	○	
P070	Low-speed zero-return frequency	0.00 – 10.00 (Hz)	0.00	0.00	0.00	×	○	○	
P071	High-speed zero-return frequency	0.00 – 99.99 / 100.0 – Maximum frequency setting, 1st motor (Hz)	0.00	0.00	0.00	×	○	○	
P072	Position range specification (forward)	0 – 268435455 (when P012 = 02) 0 – 1073741823 (When P012 = 03) (upper 4 digits)	268435455			×	○	○	
P073	Position range specification (reverse)	-268435455 – 0 (when P012 = 02) -1073741823 - 0 (When P012 = 03) (upper 4 digits)	-268435455			×	○	○	
P074	Teaching selection	00 (X00) / 01 (X01) / 02 (X02) / 03 (X03) / 04 (X04) / 05 (X05) / 06 (X06) / 07 (X07)	00	00	00	×	○	○	
P100	Easy sequence user parameter U (00)-(31)	0. to 9999., 1000 to 6553 (10000 to 65535)	0.	0.	0.	0.	○	○	
P131			0.	0.	0.	0.	○	○	

● U GROUP: USER-SELECTABLE MENU FUNCTIONS

[○= Allowed ×= Not permitted]

Code	Function Name	Monitored data or setting	Default Setting				L700	Setting during operation (allowed or not)	Change during operation (allowed or not)
			SJ700						
			-FE(CE)	-FU(UL)	-F(JP)				
U001 P012	User selected functions 1-12	no/d001 to P131	no	no	no	no	○	○	

PROTECTIVE FUNCTIONS

Name	Cause(s)	Display on digital operator	Display on remote operator/copy unit	
Over-current protection	The inverter output was short-circuited, or the motor shaft is locked or has a heavy load. These conditions cause excessive current for the inverter, so the inverter output is turned off.	While at constant speed	E01	OC.Drive
		During deceleration	E02	OC.Decel
		During acceleration	E03	OC.Accel
		Others	E04	Over.C
Overload protection(*1)	When a motor overload is detected by the electronic thermal function, the inverter trips and turns off its output.	E05	Over.L	
Braking resistor overload protection	When the regenerative braking resistor exceeds the usage time allowance or an over-voltage caused by the stop of the BRD function is detected, the inverter trips and turns off its output.	E06	OL.BRD	
Over-voltage protection	When the DC bus voltage exceeds a threshold, due to regenerative energy from the motor, the inverter trips and turns off its output.	E07	Over.V	
EEPROM error(*2)	When the built-in EEPROM memory has problems due to noise or excessive temperature, the inverter trips and turns off its output.	E08	EEPROM	
Under-voltage error	A decrease of internal DC bus voltage below a threshold results in a control circuit fault. This condition can also generate excessive motor heat or cause low torque. The inverter trips and turns off its output.	E09	Under.V	
CT(Current transformer) error	If a strong source of electrical interference is close to the inverter or abnormal operations occur in the built-in CT, the inverter trips and turns off its output.	E10	CT	
CPU error	When a malfunction in the built-in CPU has occurred, the inverter trips and turns off its output.	E11	CPU	
External trip	When a signal to an intelligent input terminal configured as EXT has occurred, the inverter trips and turns off its output.	E12	EXTERNAL	
USP error	An error occurs when power is cycled while the inverter is in RUN mode if the Unattended Start Protection (USP) is enabled. The inverter trips and does not go into RUN mode until the error is cleared.	E13	USP	
Ground fault	The inverter is protected by the detection of ground faults between the inverter output and the motor during power-up tests. This feature protects the inverter only.	E14	GND.Fit.	
Input over-voltage protection	When the input voltage is higher than the specified value, it is detected 60 seconds after power-up and the inverter trips and turns off its output.	E15	OV.SRC	
Instantaneous power failure	When power is cut for more than 15ms, the inverter trips and turns off its output. If power failure continues, the error will be cleared. The inverter restarts if it is in RUN mode when power is cycled.	E16	Inst.P-F	
Temperature error due to low cooling-fan speed	The inverter will display the error code shown on the right if the lowering of cooling-fan speed is detected at the occurrence of the temperature error described below.	E20	OH.stFAN	
Inverter thermal trip	When the inverter internal temperature is higher than the specified value, the thermal sensor in the inverter module detects the higher temperature of the power devices and trips, turning off the inverter output.	E21	OH.FIN	
Gate array error	Communication error has occurred between CPU and gate array.	E23	GA.COM	
Phase loss detection	One of three lines of 3-phase power supply is missing.	E24	PH.Fail	
Main circuit error (*3)	The inverter will trip if the gate array cannot confirm the on/off state of IGBT because of a malfunction due to noise or damage to the main circuit element.	E25	Main.Cir	
Cooling-fan speed drop signal	If the rotation speed of the internal cooling fan decreases so that the cooling effect decreases, inverter output turns OFF for protection. (available only for SJ700 1850-4000)	E29	Fan. Slow	
IGBT error	When an instantaneous over-current has occurred, the inverter trips and turns off its output to protect main circuit element.	E30	IGBT	
Thermistor error	When the thermistor inside the motor detects temperature higher than the specified value, the inverter trips and turns off its output.	E35	TH	
Braking error (*5)	The inverter turns off its output when it can not detect whether the braking is ON or OFF within waiting time set at b024 after it has released the brake. (When braking is enabled at b120)	E36	BRAKE	
Emergency stop (*4)	If the EMR signal (on three terminals) is turned on when the slide switch (SW1) on the logic board is set to ON, the inverter hardware will shut off the inverter output and display the error code shown on the right.	E37	EMR	
Low-speed overload protection	If overload occurs during the motor operation at a very low speed at 0.2 Hz or less, the electronic thermal protection circuit in the inverter will detect the overload and shut off the inverter output. (2nd electronic thermal control) (Note that a high frequency may be recorded as the error history data.)	E38	OL-LowSP	
Modbus communication error	If timeout occurs because of line disconnection during the communication in Modbus-RTU mode, the inverter will display the error code shown on the right. (The inverter will trip according to the setting of "C076".)	E41	NET.ERR	
Out of operation due to under-voltage	Due to insufficient voltage, the inverter has turned off its output and been trying to restart. If it fails to restart, it goes into the under-voltage error.	----	UV.WAIT	
Easy sequence function Error	Error indications by protective functions with the easy sequence function used.	E43	PRG.CMD	
		E44	PRG.NST	
		E45	PRG.ERR1	
Expansion card 1 connection error	An error has been detected in an expansion card or at its connecting terminals.	E60~E69	OP1-0 ~ OP1-9	
Expansion card 2 connection error		E70~E79	OP2-0 ~ OP2-9	

*1: Reset operation is acceptable 10 seconds after the trip.

*2: Check the parameters when EEPROM error occurs.

*3: The inverter will not accept reset commands input via the RS terminal or entered by the STOP/RESET key. Therefore, turn off the inverter power.

*4: The inverter will not accept the reset command entered from the digital operator. Therefore, reset the inverter by turning on the RS terminal.

*5: L700 series: The function is not provided.

〈Status Display〉

Code	Description	Code	Description	Code	Description	Code	Description	Code	Description
0	Reset	2	Deceleration	4	Acceleration	6	Starting	8	Overload Restriction
1	Stop	3	Constant Speed	5	f0 Stop	7	DB	9	Forcible or servo-on

〈How to access the details about the present fault〉

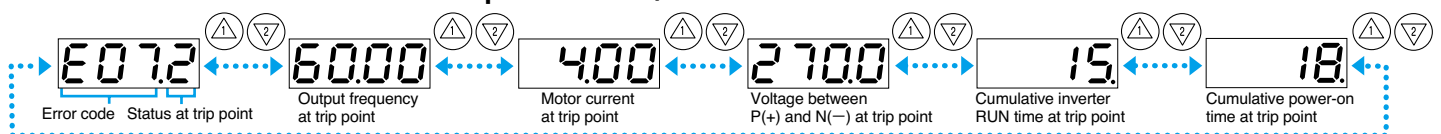

CONNECTING DIAGRAM

● Source type logic

200V class 200V-240V+10%, -15%
50/60Hz±5%
400V class 380V-480V+10%, -15%
50/60Hz±5%

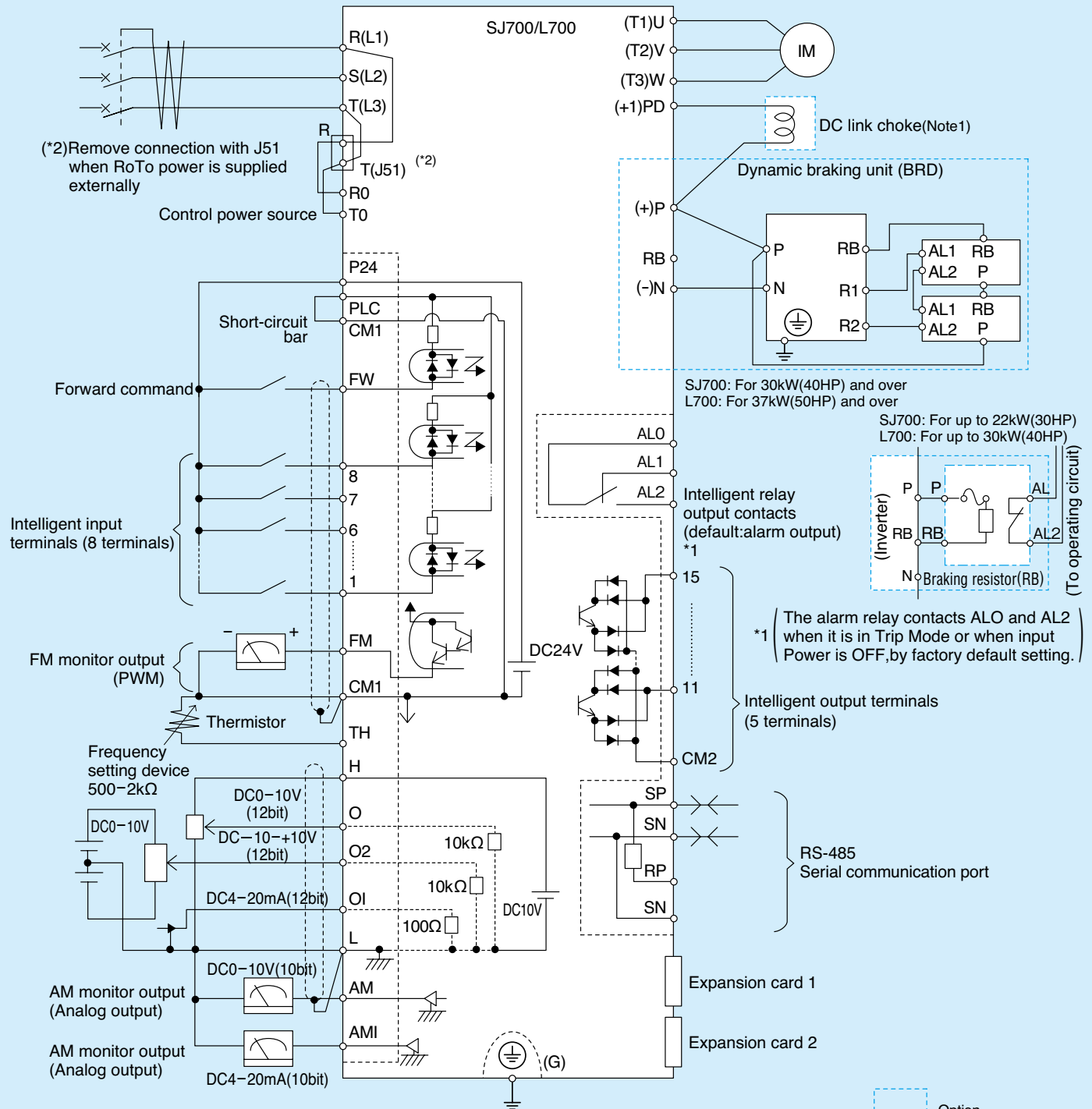

Terminal Name	FW, 1, 2, 3, 4, 5, 6, 7, 8	FM, TH	H, O, O2, OI, AM, AMI	11, 12, 13, 14, 15
Common terminal	P24	CM1	L	CM2

Note1: Please be sure to connect DC reactor attached to 4000HF.

CONNECTING DIAGRAM

● Sink type logic

200V class 200V-240V+10%, -15%
50/60Hz±5%
400V class 380V-480V+10%, -15%
50/60Hz±5%

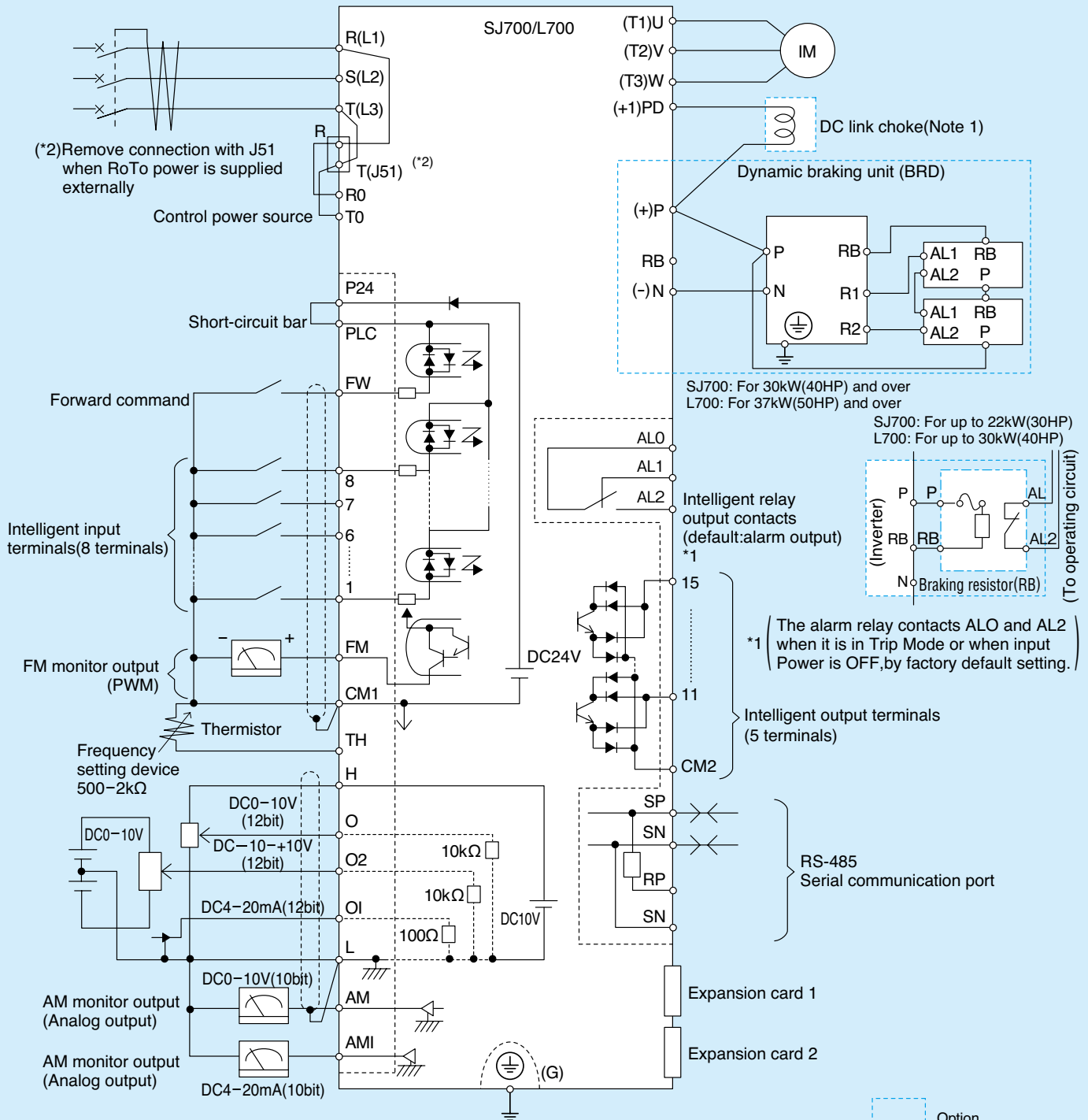

Terminal Name	FW, 1, 2, 3, 4, 5, 6, 7, 8, FM, TH	H, O, O2, OI, AM, AMI	11, 12, 13, 14, 15
Common terminal	CM1	L	CM2

Option
Customer wiring (Outside the inverter)

Note1: Please be sure to connect DC reactor attached to 4000HF.

CONNECTING TO PLC

● CONNECTION WITH INPUT TERMINALS

1. USING INTERNAL POWER SUPPLY OF THE INVERTER

(1) Sink type logic

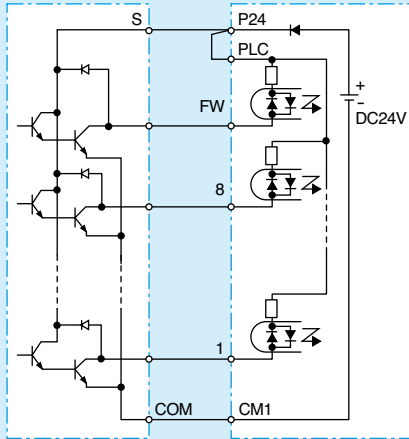

Hitachi EH-150 series PLC
Output Module
EH-YT16

(2) Source type logic

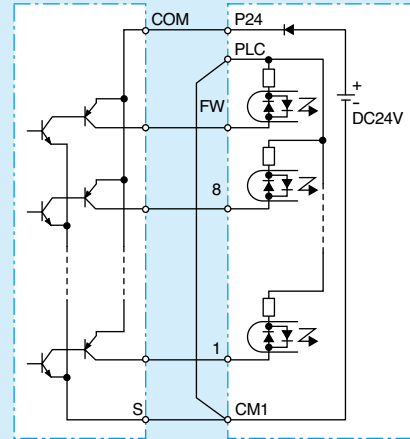

Hitachi EH-150 series PLC
Output Module
EH-YTP16

(Note: Place short-circuit bar between PLC and CM1 instead of P24 and PLC)

2. USING EXTERNAL POWER SUPPLY

(1) Sink type logic

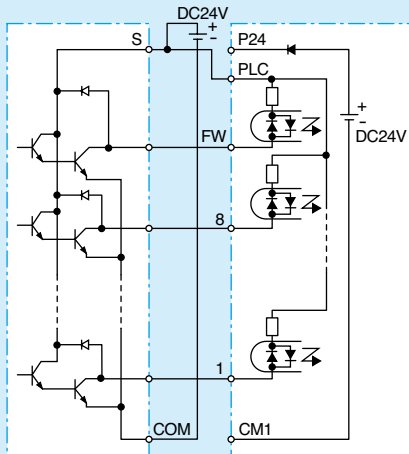

Hitachi EH-150 series PLC
Output Module
EH-YT16

(Note: Remove short-circuit bar between P24 and PLC)

(2) Source type logic

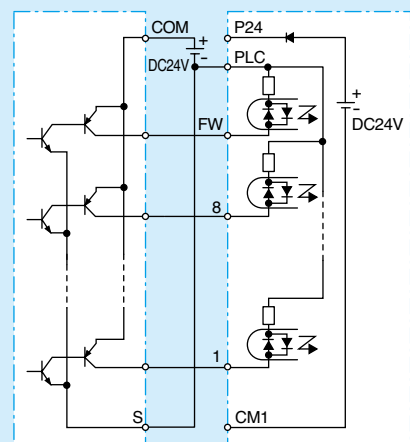

Hitachi EH-150 series PLC
Output Module
EH-YTP16

(Note: Remove short-circuit bar between P24 and PLC)

(Note: Be sure to turn on the inverter after turning on the PLC and its external power source to prevent the parameters in the inverter from being modified.)

● CONNECTION WITH OUTPUT TERMINALS

(1) Sink type logic

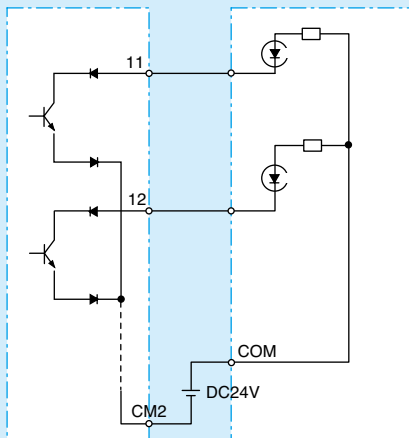

Inverter

Hitachi EH-150 series PLC
Input Module
EH-XD16

(2) Source type logic

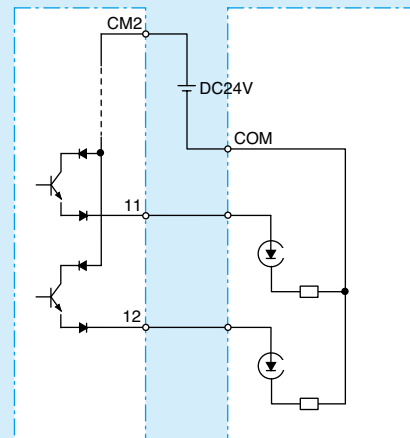

Inverter

Hitachi EH-150 series PLC
Input Module
EH-XD16

WIRING and ACCESSORIES

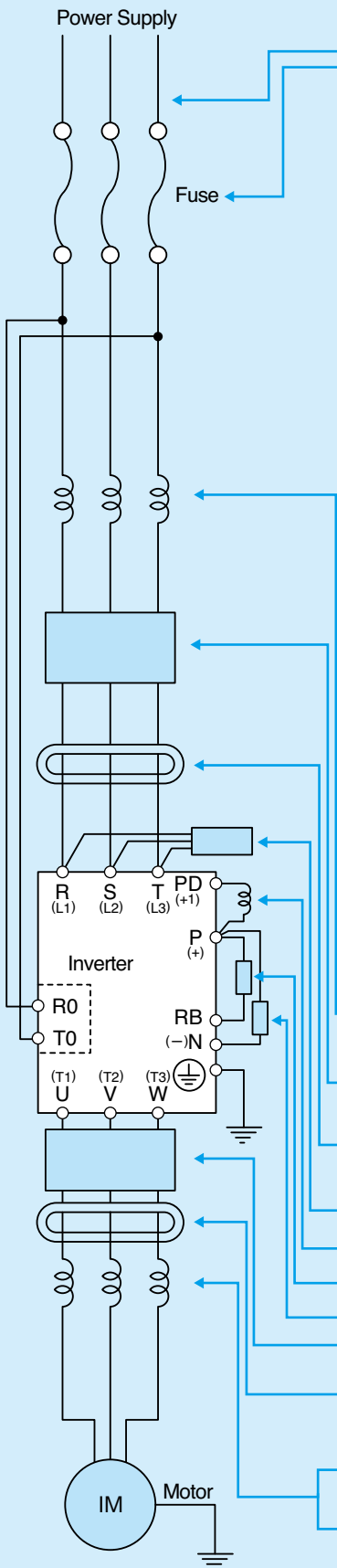

Input Voltage	Motor Output (kW(HP))	Model		Wiring				Signal Lines	Fuse (Class J)	
				Power Lines		Signal Lines			SJ700	L700
		AWG	mm ²	AWG	mm ²	SJ700	L700			
200V	0.4(1/2)	004LFUF2,LFF2	-	14	2.1	-	-	-	5	-
	0.75(1)	007LFUF2,LFF2	-	14	2.1	-	-	-	10	-
	1.5(2)	015LFUF2,LFF2	-	14	2.1	-	-	-	15	-
	2.2(3)	022LFUF2,LFF2	-	14	2.1	-	-	-	20	-
	3.7(5)	037LFUF2,LFF2	-	10	5.3	-	-	-	30	-
	5.5(7.5)	055LFUF2,LFF2	-	8	8.4	-	-	-	30	-
	7.5(10)	075LFUF2,LFF2	-	6	13.3	-	-	-	40	-
	11(15)	110LFUF2,LFF2	110LFF	6	13.3	6	13.3	-	60	40
	15(20)	150LFUF2,LFF2	150LFF	2	33.6	6	13.3	-	80	60
	18.5(25)	185LFUF2,LFF2	185LFF	1	42.4	2	33.6	-	100	80
	22(30)	220LFUF2,LFF2	220LFF	1	42.4	1	42.4	-	125	100
	30(40)	300LFUF2,LFF2	300LFF	2/0	67.4	1	42.4	-	150	125
	37(50)	370LFUF2,LFF2	370LFF	4/0	107.2	2/0	67.4	-	175	150
	45(60)	450LFUF2,LFF2	450LFF	4/0	107.2	4/0	107.2	-	225	175
	55(75)	550LFUF2,LFF2	550LFF	2/0X2	67.4X2	4/0	107.2	-	250	225
	75(100)	-	750LFF	-	-	2/0X2	67.4X2	-	-	250
	400V	0.75(1)	007HFEF2,HFUF2,HFF2	-	14	2.1	-	-	-	5
1.5(2)		015HFEF2,HFUF2,HFF2	-	14	2.1	-	-	-	10	-
2.2(3)		022HFEF2,HFUF2,HFF2	-	14	2.1	-	-	-	10	-
3.7(5)		037HFEF2,HFUF2,HFF2	-	14	2.1	-	-	-	15	-
5.5(7.5)		055HFEF2,HFUF2,HFF2	-	12	3.3	-	-	-	15	-
7.5(10)		075HFEF2,HFUF2,HFF2	-	10	5.3	-	-	-	15	-
11(15)		110HFEF2,HFUF2,HFF2	110HFF	8	8.4	8	8.4	-	20	30
15(20)		150HFEF2,HFUF2,HFF2	150HFF	6	13.3	6	13.3	-	30	40
18.5(25)		185HFEF2,HFUF2,HFF2	185HFF	6	13.3	6	13.3	-	40	50
22(30)		220HFEF2,HFUF2,HFF2	220HFF	6	13.3	6	13.3	-	50	60
30(40)		300HFEF2,HFUF2,HFF2	300HFF	3	26.7	3	26.7	-	50	70
37(50)		370HFEF2,HFUF2,HFF2	370HFF	1	42.4	1	42.4	-	60	90
45(60)		450HFEF2,HFUF2,HFF2	450HFF	1	42.4	1	42.4	-	70	125
55(75)		550HFEF2,HFUF2,HFF2	550HFF	2/0	67.4	2/0	67.4	-	90	125
75(100)		750HFEF2,HFUF2,HFF2	750HFF	1/0X2	53.5X2	1/0X2	53.5X2	-	225	225
90(125)		900HFEF2,HFUF2,HFF2	900HFF	1/0X2	53.5X2	1/0X2	53.5X2	-	225	225
110(150)		1100HFEF2,HFUF2,HFF2	1100HFF	3/0X2	85.0X2	3/0X2	85.0X2	-	300	300
132(175)		1320HFEF2,HFF2	1320HFF	3/0X2	85.0X2	3/0X2	85.0X2	-	300	300
150(200)		1500HFUF2	-	3/0X2	85.0X2	-	-	-	300	-
160(220)		-	1600HFF	-	-	3/0X2	85.0X2	-	-	300
185(250)	1850HFE2,HFU2,HF2	-	300X2	152X2	-	-	-	700	-	
220(300)	2200HFE2,HFU2,HF2	-	350X2	177X2	-	-	-	700	-	
315(400)	3150HFE2,HFU2,HF2	-	500X2	253X2	-	-	-	700	-	
400(550)	4000HFE2,HFU2,HF2	-	800X2	405X2	-	-	-	1000	-	

Note 1: Field wiring connection must be made by a UL and c-UL listed closed-loop terminal connector sized for the wire gauge involved. Connector must be fixed using the crimping tool specified by the connector manufacture.
 Note 2: Be sure to use large wire gauges for power wiring if the distance exceeds 20m (66ft).

Name	Function
Input side AC reactor	This is useful in suppressing harmonics induced on the power supply lines, or when the main power voltage imbalance exceeds 3% (and power source capacity is more than 500kVA), or to smooth out line fluctuations. It also improves the power factor.
EMI filter	Reduces the conducted noise on the power supply wiring generated by the inverter. Connect to the inverter input side.
Radio noise filter	Electrical noise interference may occur on nearby equipment such as a radio receiver. This magnetic choke filter helps reduce radiated noise (can also be used on output).
Radio noise filter (Capacitor filter)	This capacitor filter reduces radiated noise from the main power wires in the inverter input side.
DC link choke	Suppresses harmonics generated by the inverter.
Braking resistor	This is useful for increasing the inverter's control torque for high duty-cycle (on-off) applications, and improving the decelerating capability.
Braking unit	
Output side noise filter	Reduces radiated noise from wiring in the inverter output side.
Radio noise filter	Electrical noise interference may occur on nearby equipment such as a radio receiver. This magnetic choke filter helps reduce radiated noise (can also be used on input).
AC reactor	This reactor reduces the vibration in the motor caused by the inverter's switching waveforms, by smoothing the waveforms to approximate commercial power quality. It is also useful when wiring from the inverter to the motor is more than 10m in length, to reduce harmonics.
LCR filter	Sine wave shaping filter for the output side.

Note: An EMI filter is required for European EMC directive and C-Tick, but the others are not for this purpose.

DIFFERENCE and COMPATIBILITY of SJ300 series and SJ700 series

Items		SJ300 series		SJ700 series		
Copying the parameter settings		you can copy the parameter settings from the SJ300 series into the SJ700 series. (you cannot copy the parameter settings from the SJ700 series to the SJ300 series because the SJ700 series has many new functions and additional parameters.)				
Parameter display mode.		No display mode selection. (full display)		Basic display mode/Data comparison function addition. Note:basic display mode (factory setting) To display all parameters, specify "00" for "b037".		
Change function	Retry or trip parameter	Instantaneous power failure/under-voltage/ overvoltage/overcurrent:It sets up by b001.		Instantaneous power failure/under-voltage:It sets up by b001. overvoltage/overcurrent:It sets up by b008.		
	d001: Output frequency monitoring d007: Scaled output frequency monitoring	you can not change the output frequency setting by using the \triangle and/or ∇ key.		you can not change the output frequency setting by using the \triangle and/or ∇ key.		
	A016:External frequency filter time const.	Default:8		Default:31 Note 1		
	A038:Jog frequency setting	Setting range:0 to 9.99Hz		Setting range: 0.01 to 9.99Hz(0Hz setup is impossible)		
	A105:[O]-[L] input start frequency enable	Default:01(0Hz)		Default:00(external start frequency)		
	b012, b212, b312: Electronic thermal function	Setting upper limit:120%		Setting upper limit:100%		
	C025:Terminal [15] function	Default:08(instantaneous power failure)		Default:40(cooling-fan speed drop)		
Terminal	Control Circuit	Removable		Removable (You can mount the SJ300 series into the SJ700 series.)		
		Position		Other model:same position. 055L/H:5mm upper part from SJ300. 300L/H:97mm upper part from SJ300.		
	Main Circuit	Screw diameter	110L/H	M6(Ground Screw)	M5(Ground Screw)	
			300L	M8(Ground Screw)	M6(Ground Screw)	
			450L	M10	M8	
			370H	M6	M8	
		Position	055 to 110L/H:10mm upper part from SJ300. 150 to 300L/H:20mm upper part from SJ300.550L:30mm upper part from SJ300. Other model:same position.			
		Arrangement	055 to 110L/H:Two steps, 150 to 550L/H:One step		055 to 550L/H:One step	
	Others	150 to 220L/H:RB there is not a terminal.		150 to 220L/H:RB there is a terminal.		
	Easy-removable Dc bus Capacitor		All the models are possible.		15kW or more is possible.	
Dynamic Brake circuit		up to 11kW		up to 22kW		
Minimum value of resistor(Ω)	055L	17		16		
	075L	17		10		
	110L	17		10		
	055H	50		35		
	075H	50		35		
Dimensions	Installation	055L/H: SJ700 is in next larger enclosure vs. SJ300. All other models are the same enclosure size.				
	External radiating fin	055L/H:Those with no compatibility.075 to 550L/H:Those with compatibility. Note 2				
Board thickness for installation	004~037L/H	7.5mm		1.2mm		
	055~110L/H	7.5mm		13.6mm		
Digital operator position		055L/H:5mm upper part from SJ300. 300L/H:97mm upper part from SJ300. Other model:same position.				
Option boards	SJ-DG	Those with compatibility.				
	SJ-FB					
	SJ-DN/SJ-DN2	Those with compatibility. Note:Since the SJ700 series has many new functions and additional parameters, some functions of the SJ-DN, SJ-LW, and SJ-PBT (option boards conforming to the open network specifications) cannot be implemented on the SJ700 series. SJ-DN2 has compatibility to SJ700.				
	SJ-LW					
	SJ-PBT					
	Option position	Other model:same position. 055L/H:5mm upper part from SJ300. 300L/H:97mm upper part from SJ300.				

Note1:Since a response falls the V/F characteristic curve selection SLV should make this setup small.

Note2:370, 450L/H and 550H: Metal fittings differ.

DIFFERENCE and COMPATIBILITY of L300P series and L700 series

Items		L300P series	L700 series	
Copying the parameter settings		You can copy the parameter settings from the L300P series into the L700 series. (You cannot copy the parameter settings from the L700 series to the L300P series because the L700 series has many new functions and additional parameters.)		
Parameter display mode.		No display mode selection. (full display)	Basic display mode/Data comparison function addition. Note:basic display mode [factory setting])To display all parameters, specify "00" for "b037".	
Change function	Retry or trip parameter	Instantaneous power failure/under-voltage/ overvoltage/overcurrent:It sets up by b001.	Instantaneous power failure/under-voltage:It sets up by b001. overvoltage/overcurrent:It sets up by b008.	
	d001:Output frequency monitoring d007:Scaled output frequency monitoring	You can not change the output frequency setting by using the up and or down key.	You can not change the output frequency setting by using the up and or down key.	
	A001: Frequency source setting	Default:00 (Keypad potentiometer on digital operator)	Default:02 (Digital operator)	
	A016: External frequency filter time const.	Default:8	Default:31 Note 1	
	A038:Jog frequency setting	Setting range:0 to 9.99Hz	Setting range: 0.01 to 9.99Hz(0Hz setup is impossible)	
	A105: [O]-[L] input start frequency enable	Default:01(0Hz)	Default:00(external start frequency)	
	b012, b212, b312: Electronic thermal function	Setting upper limit:120%	Setting upper limit:100%	
	b013, b213, b313: Electronic thermal characteristic	Default:00 (reduced-torque characteristic)	Default:01 (constant-torque characteristic)	
	b092:Cooling fan control	Default:00 (always operating the fan)	Default:01 (operating the fan only during inverter operation [including 5 minutes after power-on and power-off])	
b095:Dynamic braking control	Default:00 (disabling)	Default:01 (enabling [disabling while the motor is topped])		
Terminal	Control circuit	Removable	Removable (You can mount the L300P into the L700 .)	
		Intelligent input terminals	5 terminals	
		Intelligent output terminals	2 terminals(Relay)	
		Position	370L/H:97mm upper part from L300P. Other model:same position.	
	Main circuit	Screw diameter	150L/H	M6(Ground Screw)
			370L	M8(Ground Screw)
			550L	M10
			450H	M6
		Position	110,150LF/HF:10mm upper part from L300P. 185 to 370L/H:20mm upper part from L300P. 750L:30mm upper part from L300P. Other model:same position.	
		Others	185 to 300L/H:RB there is not a terminal.	185 to 300L/H:RB there is a terminal.
Easy-removable Dc bus Capacitor		All the models are possible.	18.5kW or more is possible.	
Dynamic Brake circuit		Up to 15kW	Up to 30kW	
Minimum value of resistor(Ω)	110L	17	10	
	150L	17	10	
	110H	50	35	
	150H	50	35	
Dimensions	Installation	All models are the same enclosure size.		
	External radiating fin	Those with compatibility. Note 2		
Board thickness for installation	110~150L/H	7.5mm	13.6mm	
Digital operator position		300L/H:97mm upper part from L300P. Other model:same position.		
Keypad potentiometer on digital operator		Yes.	No.(Option)	
Option boards	SJ-DG	Those with compatibility.		
	SJ-DN/SJ-DN2	Those with compatibility. Note:Since the L700 series has many new functions and additional parameters,some functions of the SJ-DN, SJ-LW, and SJ-PBT(option boards conforming to the open network specifications)cannot be implemented on the L700 series.		
	SJ-LW			
	SJ-PBT	SJ-DN2 has compatibility to SJ700.		
	Option position	370L/H:97mm upper part from L300P. Other model:same position.		

Note1:Since a response falls the V/F characteristic curve selection SLV should make this setup small.

Note2:450, 550L/H and 750H:Metal fittings differ.

FOR CORRECT OPERATION

● Application to Motors

[Application to general-purpose motors]

Operating frequency	The overspeed endurance of a general-purpose motor is 120% of the rated speed for 2 minutes (JIS C4,004). For operation at higher than 60Hz, it is required to examine the allowable torque of the motor, useful life of bearings, noise, vibration, etc. In this case, be sure to consult the motor manufacturer as the maximum allowable rpm differs depending on the motor capacity, etc.
Torque characteristics	The torque characteristics of driving a general-purpose motor with an inverter differ from those of driving it using commercial power (starting torque decreases in particular). Carefully check the load torque characteristic of a connected machine and the driving torque characteristic of the motor.
Motor loss and temperature increase	An inverter-driven general-purpose motor heats up quickly at lower speeds. Consequently, the continuous torque level (output) will decrease at lower motor speeds. Carefully check the torque characteristics vs speed range requirements.
Noise	When run by an inverter, a general-purpose motor generates noise slightly greater than with commercial power.
Vibration	When run by an inverter at variable speeds, the motor may generate vibration, especially because of (a) unbalance of the rotor including a connected machine, or (b) resonance caused by the natural vibration frequency of a mechanical system. Particularly, be careful of (b) when operating at variable speeds a machine previously fitted with a constant speed motor. Vibration can be minimized by (1) avoiding resonance points using the frequency jump function of the inverter, (2) using a tire-shaped coupling, or (3) placing a rubber shock absorber beneath the motor base.
Power transmission mechanism	Under continued, low-speed operation, oil lubrication can deteriorate in a power transmission mechanism with an oil-type gear box (gear motor) or reducer. Check with the motor manufacturer for the permissible range of continuous speed. To operate at more than 60 Hz, confirm the machine's ability to withstand the centrifugal force generated.

[Application to special motors]

Gear motor	The allowable rotation range of continuous drive varies depending on the lubrication method or motor manufacturer. (Particularly in case of oil lubrication, pay attention to the low frequency range.)
Brake-equipped motor	For use of a brake-equipped motor, be sure to connect the braking power supply from the primary side of the inverter.
Pole-change motor	There are different kinds of pole-change motors (constant output characteristic type, constant torque characteristic type, etc.), with different rated current values. In motor selection, check the maximum allowable current for each motor of a different pole count. At the time of pole changing, be sure to stop the motor. Also see: Application to the 400V-class motor.
Submersible motor	The rated current of a submersible motor is significantly larger than that of the general-purpose motor. In inverter selection, be sure to check the rated current of the motor.
Explosion-proof motor	Inverter drive is not suitable for a safety-enhanced explosion-proof type motor. The inverter should be used in combination with a pressure-proof explosion-proof type of motor. *Explosion-proof verification is not available for SJ700 Series.
Synchronous (MS) motor High-speed (HFM) motor	In most cases, the synchronous (MS) motor and the high-speed (HFM) motor are designed and manufactured to meet the specifications suitable for a connected machine. As to proper inverter selection, consult the manufacturer.
Single-phase motor	A single-phase motor is not suitable for variable-speed operation by an inverter drive. Therefore, use a three-phase motor.

[Application to the 400V-class motor]

A system applying a voltage-type PWM inverter with IGBT may have surge voltage at the motor terminals resulting from the cable constants including the cable length and the cable laying method. Depending on the surge current magnification, the motor coil insulation may be degraded. In particular, when a 400V-class motor is used, a longer cable is used, and critical loss can occur, take the following countermeasures:

- (1) install the LCR filter between the inverter and the motor,
- (2) install the AC reactor between the inverter and the motor, or
- (3) enhance the insulation of the motor coil.

● Notes on Use

[Drive]

Run/Stop	Run or stop of the inverter must be done with the keys on the operator panel or through the control circuit terminal. Do not operate by installing an electromagnetic contactor (Mg) in the main circuit.
Emergency motor stop	When the protective function is operating or the power supply stops, the motor enters the free run stop state. When an emergency stop is required or when the motor should be kept stopped, use of a mechanical brake should be considered.
High-frequency run	A max. 400Hz can be selected on the SJ700 and L700 Series. However, a two-pole motor can attain up to approx. 24,000 rpm, which is extremely dangerous. Therefore, carefully make selection and settings by checking the mechanical strength of the motor and connected machines. Consult the motor manufacturer when it is necessary to drive a standard (general-purpose) motor above 60 Hz. A full line of high-speed motors is available from Hitachi.

[About the load of a frequent repetition use]

About frequent repetition use (crane, elevator, press, washing machine), a power semiconductor (IGBT, a rectification diode, thyristor) in the inverter may come to remarkably have a short life by heat exhaustion. The life can be prolonged by lower a load electric current. Lengthen acceleration / deceleration time. Lower carrier frequency. or increasing capacity of the inverter.

[About the use in highlands beyond 1,000m above sea level]

When the standard inverter is used at a place beyond 1,000m above sea level because it cool heating element with air, please be careful as follows. But please inquire for the highlands more than 2,500m separately.

1. Reduction of the inverter rating current

The density of air decreases by 1% whenever rising by 100m when the altitude exceeds 1000m.

For example, in the case of 2,000m above sea level, it is $\{2,000(m) - \text{Because it becomes } 1,000(m)\} / 100(m) \times \{-1(\%)\} = -10(\%)$, please use with 10(%) reduction (0.9* inverter rating electric current) of a rating current of the inverter.

2. Reduction of the breakdown voltage

When using inverter at a place beyond 1,000m, the breakdown voltage decreases as follows.

1,000m or less : 1.00/1,500m : 0.95/2,000m : 0.90/2,500m : 0.85

But please do not perform the withstand pressure test as mention of the instruction manual.

[Installation location and operating environment]

Avoid installation in areas of high temperature, excessive humidity, or where moisture can easily collect, as well as areas that are dusty, subject to corrosive gasses, mist of liquid for grinding, or salt. Install the inverter away from direct sunlight in a well-ventilated room that is free of vibration. The inverter can be operated in the ambient temperature range from -10 to 50°C. (Carrier frequency and output current must be reduced in the range of 40 to 50°C.)

[Main power supply]

<p>Installation of an AC reactor on the input side</p>	<p>In the following examples involving a general-purpose inverter, a large peak current flows on the main power supply side, and is able to destroy the converter module. Where such situations are foreseen or the connected equipment must be highly reliable, install an AC reactor between the power supply and the inverter. Also, where influence of indirect lightning strike is possible, install a lightning conductor.</p> <p>(A) The unbalance factor of the power supply is 3% or higher. (Note)</p> <p>(B) The power supply capacity is at least 10 times greater than the inverter capacity (the power supply capacity is 500 kVA or more).</p> <p>(C) Abrupt power supply changes are expected.</p> <p>Examples:</p> <p>(1) Several inverters are interconnected with a short bus.</p> <p>(2) A thyristor converter and an inverter are interconnected with a short bus.</p> <p>(3) An installed phase advance capacitor opens and closes.</p> <p>In cases (A), (B) and (C), it is recommended to install an AC reactor on the main power supply side.</p> <p>Note: Example calculation with $V_{RS} = 205V$, $V_{ST} = 201V$, $V_{TR} = 200V$ V_{RS} : R-S line voltage, V_{ST} : S-T line voltage, V_{TR} : T-R line voltage</p> $\text{Unbalance factor of voltage} = \frac{\text{Max. line voltage (min.)} - \text{Mean line voltage}}{\text{Mean line voltage}} \times 100$ $= \frac{V_{RS} - (V_{RS} + V_{ST} + V_{TR})/3}{(V_{RS} + V_{ST} + V_{TR})/3} \times 100 = \frac{205 - 202}{202} \times 100 = 1.5 (\%)$
<p>Using a private power generator</p>	<p>An inverter run by a private power generator may overheat the generator or suffer from a deformed output voltage waveform of the generator. Generally, the generator capacity should be five times that of the inverter (kVA) in a PWM control system, or six times greater in a PAM control system.</p>

● Notes on Peripheral Equipment Selection

<p>Wiring connections</p>	<p>(1) Be sure to connect main power wires with R(L1), S(L2), and T(L3) terminals (input) and motor wires to U(T1), V(T2), and W(T3) terminals (output). (Incorrect connection will cause an immediate failure.)</p> <p>(2) Be sure to provide a grounding connection with the ground terminal (⊕).</p>
<p>Wiring between inverter and motor</p>	<p>Electromagnetic contactor</p> <p>When an electromagnetic contactor is installed between the inverter and the motor, do not perform on-off switching during running operation.</p> <p>Thermal relay</p> <p>When used with standard applicable output motors (standard three-phase squirrel-cage four-pole motors), the SJ700 and L700 Series does not need a thermal relay for motor protection due to the internal electronic protective circuit. A thermal relay, however, should be used:</p> <ul style="list-style-type: none"> ● during continuous running outside a range of 30 to 60 Hz. ● for motors exceeding the range of electronic thermal adjustment (rated current). ● when several motors are driven by the same inverter; install a thermal relay for each motor. ● The RC value of the thermal relay should be more than 1.1 times the rated current of the motor. Where the wiring length is 10 m or more, the thermal relay tends to turn off readily. In this case, provide an AC reactor on the output side or use a current sensor.
<p>Installing a circuit breaker</p>	<p>Install a circuit breaker on the main power input side to protect inverter wiring and ensure personal safety. Choose an inverter-compatible circuit breaker. The conventional type may malfunction due to harmonics from the inverter. For more information, consult the circuit breaker manufacturer.</p>
<p>Wiring distance</p>	<p>The wiring distance between the inverter and the remote operator panel should be 20 meters or less. When this distance is exceeded, use CVD-E (current-voltage converter) or RCD-E (remote control device). Shielded cable should be used on the wiring. Beware of voltage drops on main circuit wires. (A large voltage drop reduces torque.)</p>
<p>Earth leakage relay</p>	<p>If the earth leakage relay (or earth leakage breaker) is used, it should have a sensitivity level of 15 mA or more (per inverter).</p>
<p>Phase advance capacitor</p>	<p>Do not use a capacitor for power factor improvement between the inverter and the motor because the high-frequency components of the inverter output may overheat or damage the capacitor.</p>

● High-frequency Noise and Leakage Current

- (1) High-frequency components are included in the input/output of the inverter main circuit, and they may cause interference in a transmitter, radio, or sensor if used near the inverter. The interference can be minimized by attaching noise filters (option) in the inverter circuitry.
- (2) The switching action of an inverter causes an increase in leakage current. Be sure to ground the inverter and the motor.

● Lifetime of Primary Parts

Because a DC bus capacitor deteriorates as it undergoes internal chemical reaction, it should normally be replaced every 10 years. (10 years is not the guaranteed lifespan but rather, the expected design lifespan.) Be aware, however, that its life expectancy is considerably shorter when the inverter is subjected to such adverse factors as high temperatures or heavy loads exceeding the rated current of the inverter. JEMA standard is the 5 years at ambient temperature 40°C used in 12 hours daily. (according to the "Instructions for Periodic Inspection of General-Purpose Inverter" (JEMA).) Also, such moving parts as a cooling fan should be replaced. Maintenance inspection and parts replacement must be performed by only specified trained personnel.

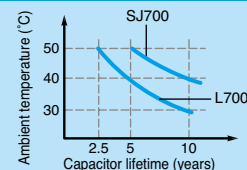

Precaution for Correct Usage

- Before use, be sure to read through the Instruction Manual to insure proper use of the inverter.
- Note that the inverter requires electrical wiring; a trained specialist should carry out the wiring.
- The inverter in this catalog is designed for general industrial applications. For special applications in fields such as aircraft, outer space, nuclear power, electrical power, transport vehicles, clinics, and underwater equipment, please consult with us in advance.
- For application in a facility where human life is involved or serious losses may occur, make sure to provide safety devices to avoid a serious accident.
- The inverter is intended for use with a three-phase AC motor. For use with a load other than this, please consult with us.

Information in this brochure is subject to change without notice.

